

Compac counter flanges

To increase the flexibility for units with standard threaded connections, SWEP offer a range of Compac flange kits. The threaded part is easily assembled to the connections and the counter flange welded to your pipe.

SWEP accessories meet the same high standards as the company's BPHEs. They are produced according to SWEP's specification by rigorously selected suppliers. The high-quality materials are carefully chosen for compatibility, while the accurate dimensions save you time and money on installation. With SWEP accessories you have the assurance that everything will fit and perform the way the design engineers intended.

Standard connections

SWEP counter flanges are used to connect your pipe to our DN compac flanges on the BPHE unit.

For more information, please contact your local SWEP representative.



Technical data *	
Max working temperature	200°C
Min working temperature	-15°C
Max working pressure	40 bar

*According properties of SWEP gasket

Material options	
Stainless steel	1.4404 alt 1.4571
Carbon steel	C22.8

Size	A (mm)	B (mm)	C (mm)	D (mm)	E (mm)	Ø F (mm)
DN20C	10	20	26,9	53	71	11
DN25C	10	20	33,7	63	84	13
DN50C	12	24	60,3	91	112	13
DN65C	12	24	76,1	106	125	13
DN80C	15	30	88,9	118	141	13
DN100C	15	30	114,3	144	165	13
DN150C	22	44	168,3	217	250	13

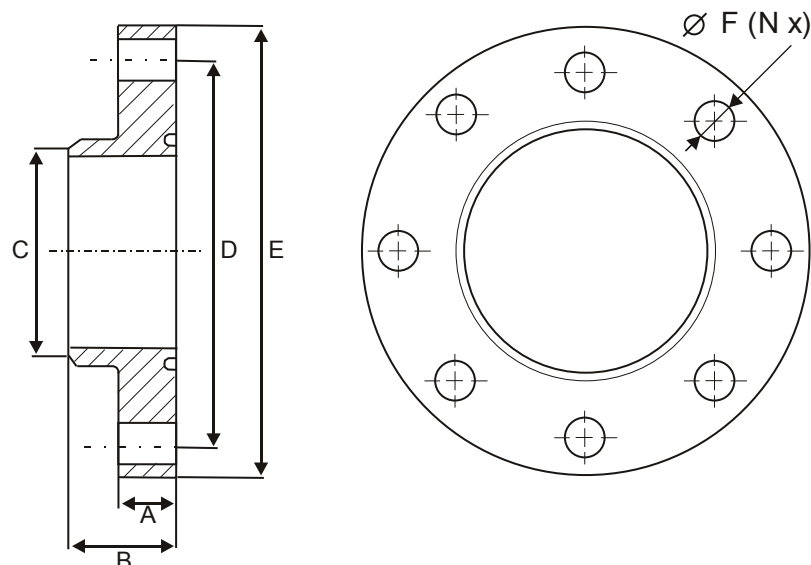

www.swep.net

SWEP
A DOVER COMPANY