

„ORIGINAL INSTRUCTIONS“

**IMPORTANT NOTE:**

Read this manual carefully before installing or operating your new heat pump.  
Make sure to save this manual for future reference.

---

Page

3	Features and benefits
5	Standard unit technical specifications
7	Accessories separately supplied
9	General technical data
12	Hydraulic connections
13	Aeraulic connections
14	Data for the UNI/TS 11300 calculation
15	Dimensional drawings

# Features and benefits

## System Description

SWH is a specialised heat pump system for producing domestic hot water. SWH reduces costs connected with the production of domestic hot water. Using heat pump technology, SWH is able to transform renewable energy contained in the air into heat, which it then uses to raise the temperature of water contained in the storage tank. The consumption of electrical power in this sequence is reduced to a minimum. SWH is 4 times more efficient than a traditional electrical boiler, which in economic terms means a 75% reduction in cost for electricity for the same amount of thermal power produced.

## TOP Efficiency

SWH reaches the highest levels of efficiency present at this moment on the market. Thanks to the careful design of the cooling circuit, it has been placed in the class A+ according to the ErP Directive. The high values of COP allow for significant savings in energy and operating costs, in addition to an increased use of renewable energy.



## Enamel Steel Tank with heat exchanger wrapped around the tank

The innovative active electronic anode and the enamelled steel tank guarantee a high level of protection against corrosion. The exchanger (condenser) consists of an ALUMINIUM coil wrapped around the outside of the domestic hot water storage tank. This feature guarantees maximum safety because it prevents any possible contamination between the refrigerant and the water. Before the Aluminium condenser is wrapped around the tank, it is shaped to obtain an innovative profile designed to maximize the surface in contact with the tank and improve thermal exchange.

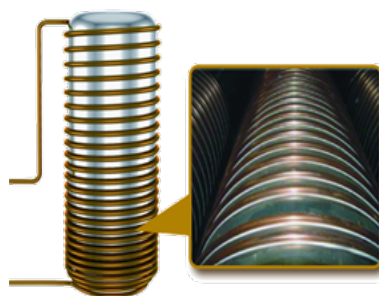

## Full Operating Limits

The use of the most advanced technologies, both in terms of components and in relation to regulating logic, allow SWH to be used in extreme temperatures. SWH can function within the air temperature range of -20°C to +43°C in combined operation (heat pump + electrical heating element) and even in the range of -7°C to +43°C with only the heat pump. Moreover, it is possible to reach hot water temperatures exceeding 65°C using only the heat pump.



## Advanced control options

SWH has a **Modbus** connection port for integration with third-party home automation systems. The unit is also compatible with **ELFOControl<sup>3</sup> EVO**, the supervision system that optimises operation of resistance systems. SWH can be integrated with **photovoltaic panels** thanks to its dedicated input, and is also set up for **Smart Grid** management. It is also possible to control SWH Plus through a **user-friendly App**: the **Wi-Fi** function is supplied as standard with the unit so that the users can display and set the main unit parameters on their smartphone.



## User Interface

To control SWH, it is possible to use the control panel mounted on the unit. The control system was designed to be quick and intuitive for the user. All parameters are easily accessible with the 9 central buttons.

The control panel allows the user to view:

- current water temperature
- unit operating status
- the operating status of the compressor and the electric heating element
- any possible malfunction

and to set:

- the SET temperature of the accumulator
- the unit's schedule, up to six activation or deactivation times
- manual activation of the electric heating element
- manual activation of the anti-legionella disinfection cycle
- switching the unit on and off

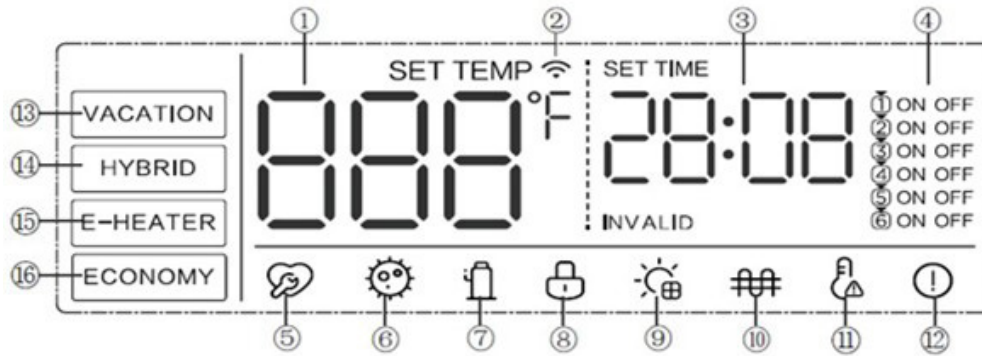
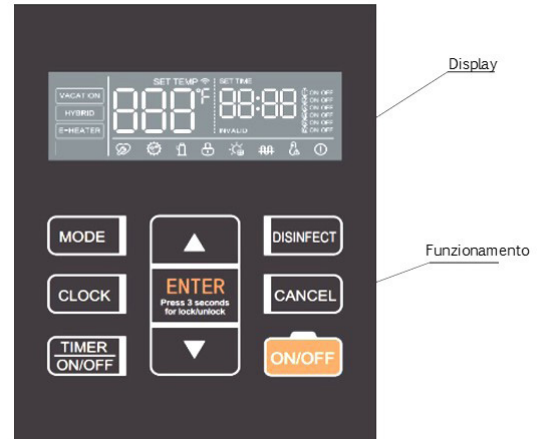

REF	ICON	DESCRIPTION	REF	ICON	DESCRIPTION
1	000°F	On: screen locked	10	#	Electric heater in operation
2	WiFi symbol	On: WiFi connected; Off: WiFi not connected; Flashing: WiFi setting up	11	High temperature alarm symbol	High temperature alarm Water temperature above 50°C
3	20:08	Indicates the time	12	! in circle	Unit in error/protection
4	6 programs can be set icon	6 programs can be set	13	VACATION button	Unit works in VACATION mode
5	Hand icon	Reserved	14	HYBRID button	Unit in HYBRID mode
6	Gear icon	Unit in disinfection cycle (antilegionella)	15	E-HEATER button	Unit in E-HEATER mode
7	Water tap icon	Compressor in operation		INVALID	An invalid button was pressed
8	Lock icon	Buttons locked		SET TEMP	On: water temperature setting
9	Sun icon	Unit connected to the solar signal or to the solar water pump		SET TIME	On: time setting

# Standard unit technical specifications

## SWH

### Fan

Centrifugal fan with plastic profile blades, housed in aerodynamically shaped nozzle to increase efficiency and minimize sound level.

### Evaporator

Evaporator coil with large surface which improves heat transfer and reduces defrost time in order to increase the seasonal efficiency.

### Anodo

Electronic anode to ensure maximum protection and durability over time.

### Handles

Lifting handles for easy installation and transportation.

### Condenser

Condenser with aluminum coil, wrapped around the tank and thus avoid the possibility of water contamination for any leaks of refrigerant. The coil is suitably shaped to maximize the contact area with the fuel tank, it is also interposed with a conductive paste to improve heat exchange between the capacitor and the accumulation.

### Compressor

Rotary ON/OFF Compressor using R134a on vibration rubber to minimize the transmission of vibration and noise.

### Safety thermostats

- Automatic temperature reset thermostat (ATCO auto temperature cut off)
- Manual reset thermostat (TCO temperature cut off)

### Modbus protocol

Allows serial connection to supervision systems, using Modbus as a communication protocol. Gives access to the entire list of operation variables, controls and alarms.

### Electric heater

1,5kW electrical element can be used for heating when the temperature is below  $-7^{\circ}\text{C}$  and/or to integrate with rigid air temperatures and high set temperatures.

### Integration exchanger

Integration exchanger vitrified steel coil of  $1.1\text{m}^2$  on 190L and  $1.3\text{m}^2$  on 300L with well for probe for regulation.

### Tank

Steel storage tank for 280/180 liters of water, internally vitrified to completely isolate water from the metal to avoid corrosion problems.

### Insulation

External insulation in polyurethane (thickness 50mm).



## Appearance



**SIZE 190**



**SIZE 190S**



**SIZE 300**



**SIZE 300S**

SIZE			190	300	190S	300S
<b>Power and Efficiency (fan included)</b>						
Tout 15/12 °C ( DB/WB), Tw,in 15 °C Tw,out 45°C	Heating capacity	kW	1,62	2,3	1,62	2,3
	Total absorbed power	kW	0,469	0,606	0,469	0,606
	COP		3,45	3,8	3,45	3,8
Tout 43/26 °C ( DB/WB), Tw,in 10 °C Tw,out 70°C--> 190 Tw,out 65°C--> 300	Heating capacity	kW	2,31	3,25	2,31	3,25
	Total absorbed power	kW	0,595	0,703	0,595	0,703
	COP		3,88	4,62	3,88	4,62
Sound pressure level (1m)		dB(A)	37,6	39,2	37,6	39,2
Sound power level (LWA)		dB(A)	52	54	52	54
<b>Additional ventilation</b>						
Type of fan			Radiale	Radiale	Radiale	Radiale
Pressure head with additional ventilation		Pa	200	240	200	240

## Electical data

SIZE			190	300	190S	300S
Standard power input	(1) V		220-240/1/50	220-240/1/50	220-240/1/50	220-240/1/50
F.L.A. - Current absorbed at the maximum allowed conditions	A		0,25	0,41	0,25	0,41
F.L.I. - Power absorbed at full load (at the maximum allowed conditions)	W		50	80	50	80
M.I.C - Maximum inrush current	A		0,32	0,78	0,32	0,78

(1) Power supply 220-240/1/50 For non-standard power supply voltages, contact the Sinclair Technical Office Units are compliant with provisions set forth in the European standards CEI EN 60204 and CEI EN 60335 Data refers to the additional fan only, to be added to the total data of the unit.

## Aeraulic Connections

DUCTED INTAKE AND EXHAUST (recommended)

Install the additional fan on the exhaust ducting close to the unit.

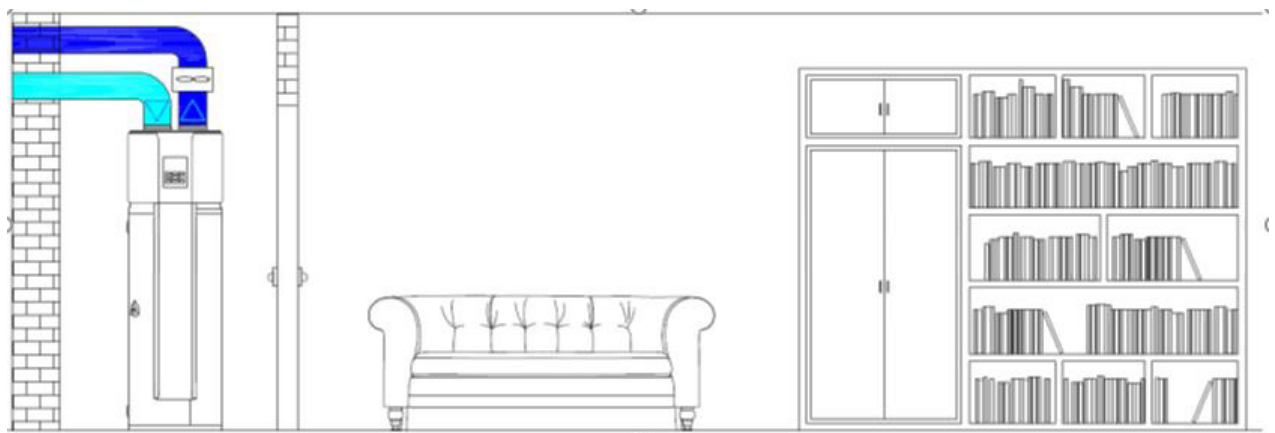



## COPX

### Accessory connection cables

The accessory includes cables to facilitate connection to the circuit board for use of the following functions:

- Solar input (only for 190S and 300S): 220-240V signal input for the solar control unit
- On/off input: contact for switching on/off the unit by external signal
- Modbus: connection for RS486 Modbus supervisory system protocol or ELFOControl3 EVO

### Solar input (only for 190S and 300S)

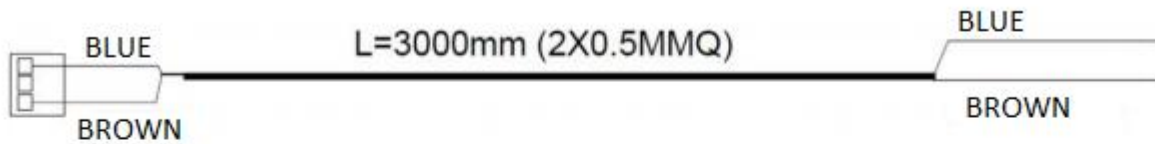

### On/off input

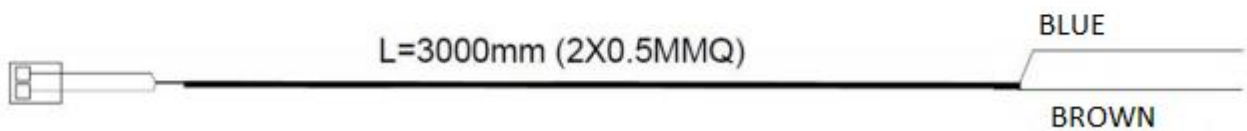

### Modbus

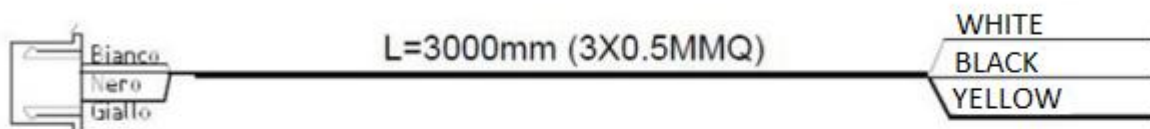

### (PUMP + XT2)

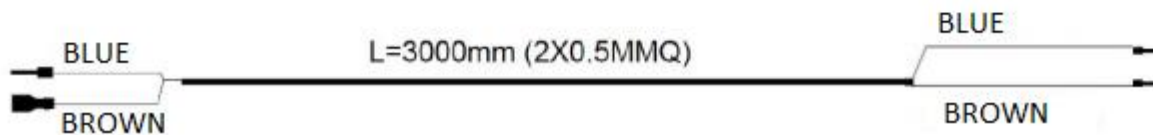

# General technical data

SIZE			190	300	190S	300S
<b>Power and Efficiency</b>						
Tout 15/12 °C ( DB/WB), Tw,in 15 °C Tw,out 45°C	Heating capacity	kW	1,62	2,30	1,62	2,30
	Total power absorbed	kW	0,42	0,53	0,42	0,53
	COP		3,86	4,34	3,86	4,34
Tout 43/26 °C ( DB/WB), Tw,in 10 °C Tw,out 70°C--> 190 Tw,out 65°C--> 300	Heating capacity	kW	2,31	3,25	2,31	3,25
	Total power absorbed	kW	0,546	0,627	0,546	0,627
	COP		4,23	5,18	4,23	5,18
Riscaldatore elettrico		kW	1,50	1,50	1,50	1,50
Standard power input		V	220-240/1/50	220-240/1/50	220-240/1/50	220-240/1/50
Heating time ACS	(1)	h/min	3/53	4/22	3/53	4/22
Maximum temperature ACS	(6)	°C	70	70	70	70
Sound pressure level (1m)	(5)	dB(A)	36,6	38,2	36,6	38,2
Sound power level (L <sub>WA</sub> )		dB(A)	51	53	51	53
<b>ERP</b>						
Clima Average Heat pumps Water Heater (2)	Energy class of generator		A+	A+	A+	A+
	DHW profile		L	XL	L	XL
	$\eta_{wh}$	%	115%	123%	115%	123%
	Annual consumption AEC	kWh	890	1356	890	1356
	Daily consumption	kWh	4,22	6,34	4,22	6,34
	COP EN 16147		2,76	3,01	2,76	3,01
Clima Warmer Heat pumps Water Heater (3)	DHW profile		L	XL	L	XL
	$\eta_{wh}$	%	125%	143%	125%	143%
	Annual consumption AEC	kWh	819	1173	819	1173
	Daily consumption	kWh	3,86	5,49	3,86	5,49
	COP EN 16147		3,13	3,59	3,13	3,59
Clima Colder Heat pumps Water Heater (4)	DHW profile		L	XL	L	XL
	$\eta_{wh}$	%	99%	91%	99%	91%
	Annual consumption AEC	kWh	1034	1845	1034	1845
	Daily consumption	kWh	4,90	8,56	4,90	8,56
	COP EN 16147		2,36	2,32	2,36	2,32
<b>DHW tank</b>						
DHW volume	l		176	284	168	272
Material of tank			Acciaio Vetrificato	Acciaio Vetrificato	Acciaio Vetrificato	Acciaio Vetrificato
Insulation Material			Poliuretano Espanso	Poliuretano Espanso	Poliuretano Espanso	Poliuretano Espanso
Heat losses	W/K		0,91	0,94	0,91	0,94
Maximum operating pressure	bar		10	10	10	10
Insulation Thickness	mm		50	50	50	50
<b>Refrigerant Circuit</b>						
Compressor type			Rotativo	Rotativo	Rotativo	Rotativo
Refrigerant			R134a	R134a	R134a	R134a
Quantity of refrigerant	kg		1,10	1,40	1,10	1,40
GWP	t		1430	1430	1430	1430
Tonne of CO2 equivalents *	t <sub>CO2</sub>		1,57	2,00	1,57	2,00
Oil quantity	ml		350	350	350	350
Type of expansion valve			Elettronica	Elettronica	Elettronica	Elettronica
<b>Fan</b>						
Type of fan			Centrifugo	Centrifugo	Centrifugo	Centrifugo
Air flow	m <sup>3</sup> /h		270	414	270	414
Available pressure head	Pa		25	45	25	45
<b>Integration</b>						
Integration coil surface	m <sup>2</sup>		-	-	1,10	1,30
Integration coil material			-	-	Acciaio Vetrificato	Acciaio Vetrificato
Maximum operating pressure	bar		-	-	10	10

- Inlet water temperature 15 °C, accumulator set 45°C, air on source side 15°C D.B /12°C W.B.
- The product complies with the European Directive ErP, which includes the Commission Delegated Regulation (EU) N. 812/2013 and the Commission Delegated Regulation N. 814/2013, Average Climate, Heat Pump Water Heater
- The product complies with the European Directive ErP, which includes the Commission Delegated Regulation (EU) N. 812/2013 and the Commission Delegated

- Regulation N. 814/2013, Warmer Climate, Heat Pump Water Heater
- The product complies with the European Directive ErP, which includes the Commission Delegated Regulation (EU) N. 812/2013 and the Commission Delegated Regulation N. 814/2013, Colder Climate, Heat Pump Water Heater
- Data referred to completely ducted unit.
- Maximum temperature that can be reached during anti-legionella mode (Disinfect)
- \* It contains fluorinated greenhouse gases

## Electrical data

SIZE		190	300	190S	300S
Power input	(1) V	220-240/1/50	220-240/1/50	220-240/1/50	220-240/1/50
F.L.A. - Current absorbed at the maximum allowed conditions	A	9,10	9,80	9,10	9,80
F.L.I. - Power absorbed at full load (at the maximum allowed conditions)	kW	2,10	2,25	2,10	2,25
M.I.C - Maximum inrush current	A	22,2	33,7	22,2	33,7

(1) Power supply 220-240/1/50

For non-standard power supply voltages, contact the SGG Technical Office. Units are compliant with provisions set forth in the European standards CEI EN 60204 and CEI EN 60335

**⚠ Warning:** when defining the correct size, verify that all absorption is compliant with current electrical supply contracts in force in the country of installation

## Operating limits

AQUA 190 - 190S

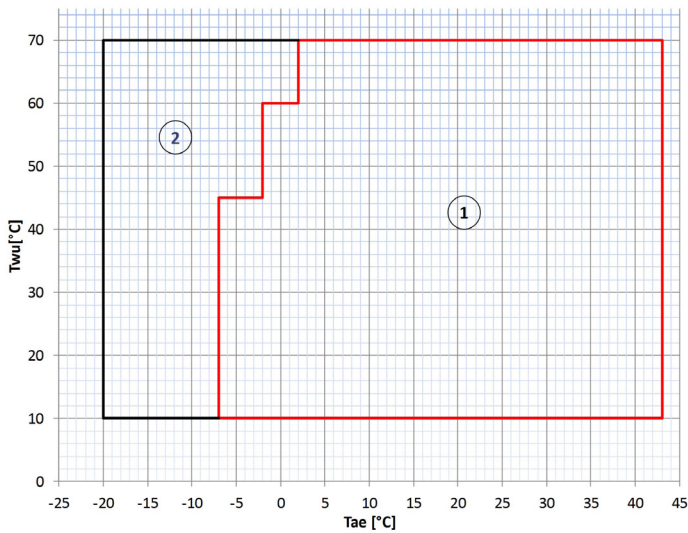

T<sub>wu</sub> [°C] = temperatura acqua accumulato  
T<sub>ae</sub> [°C] = temperatura aria ingresso scambiatore

1. Use range of the heat pump
2. Use range of the electrical heating element

AQUA 300 - 300S

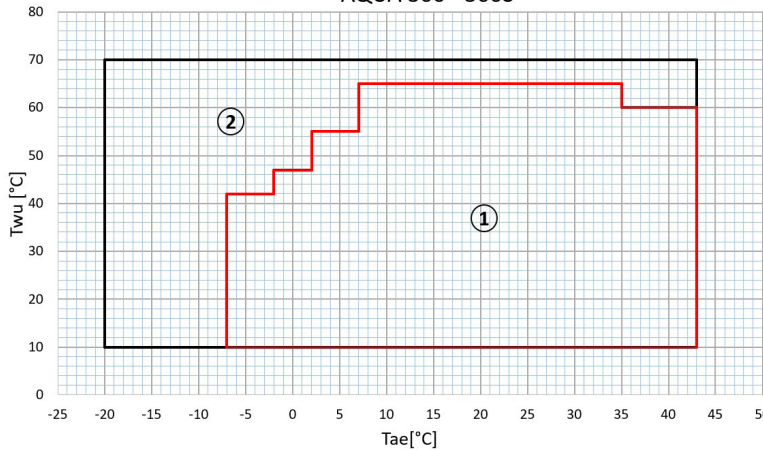

T<sub>wu</sub> [°C] = temperatura acqua accumulato  
T<sub>ae</sub> [°C]: temperatura aria ingresso scambiatore

1. Use range of the heat pump
2. Use range of the electrical heating element

# General technical data

## Performances Curve

The following curves were obtained from performance tests carried out under dynamic mode. The inlet water temperature, which coincides with the initial status 0, is temperature 10°C. The different curves represent the specific parameter (heating time, heating capacity, COP) with different set temperature (45° C-50° C-55° C-60° C-65° C to 70° C)

### Heat UP

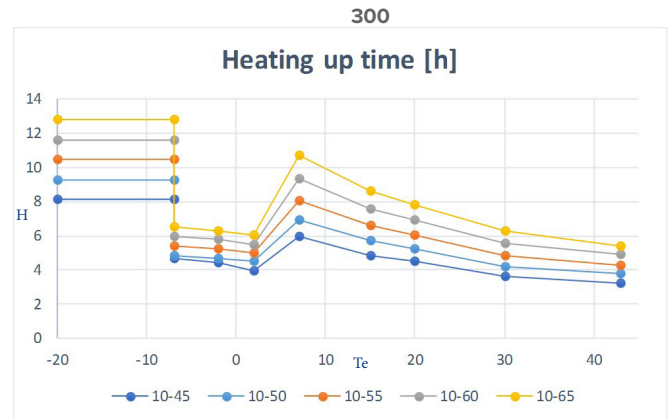
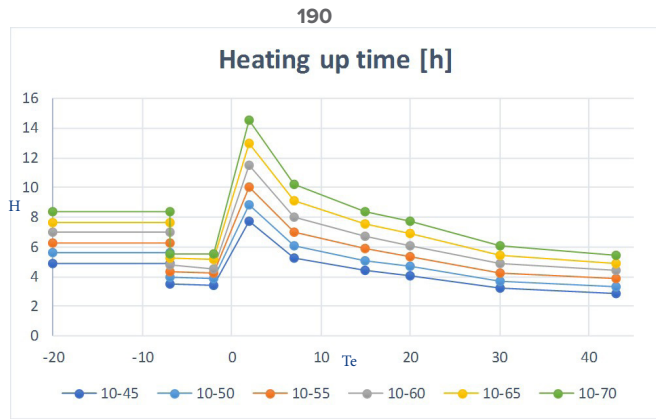

$T_e$  = Outdoor Air Temperature°C  
 $H$  = Heat Up Time (h)

### Heating capacity

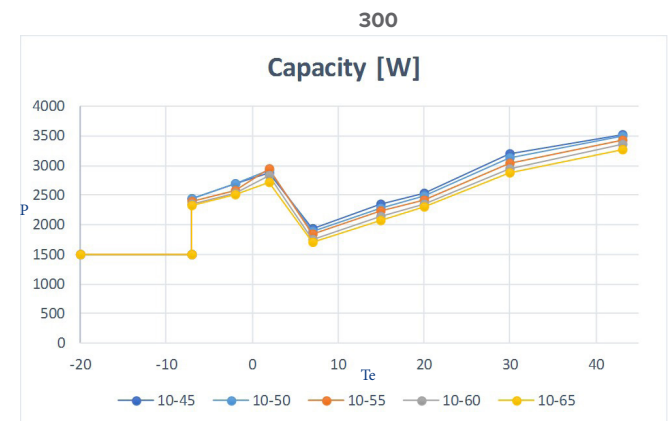
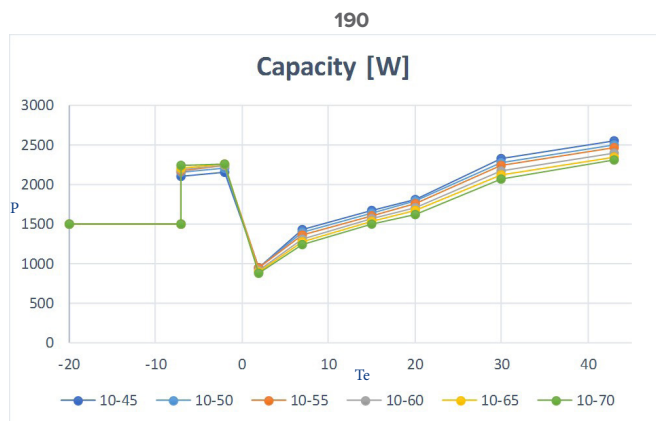

$T_e$  = Outdoor Air Temperature°C  
 $P$  = Heating Capacity (W)

### COP

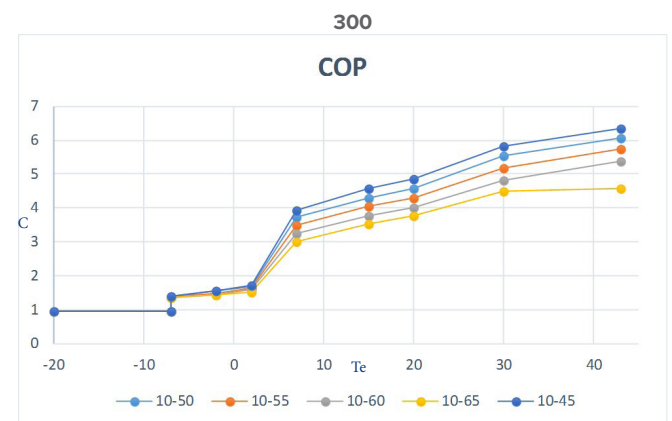
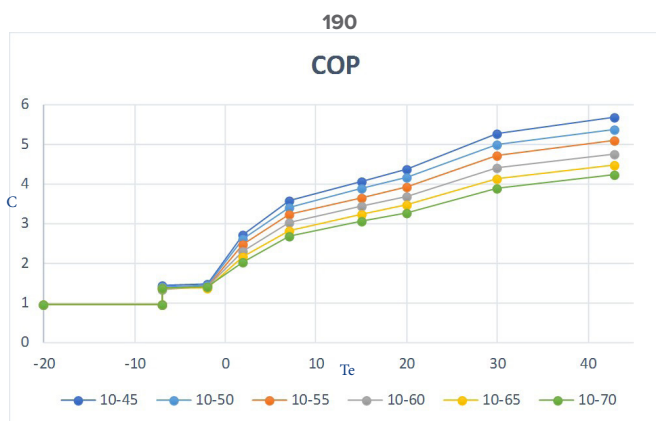

$T_e$  = Outdoor Air Temperature°C  
 $C$  = COP

# Hydraulic connections

Below are some diagrams that give an idea of the hydraulic connections in the two versions of SWH. The connection and design of the system must be done in conformity with national regulations that are currently in force.

### Size 190 - 300

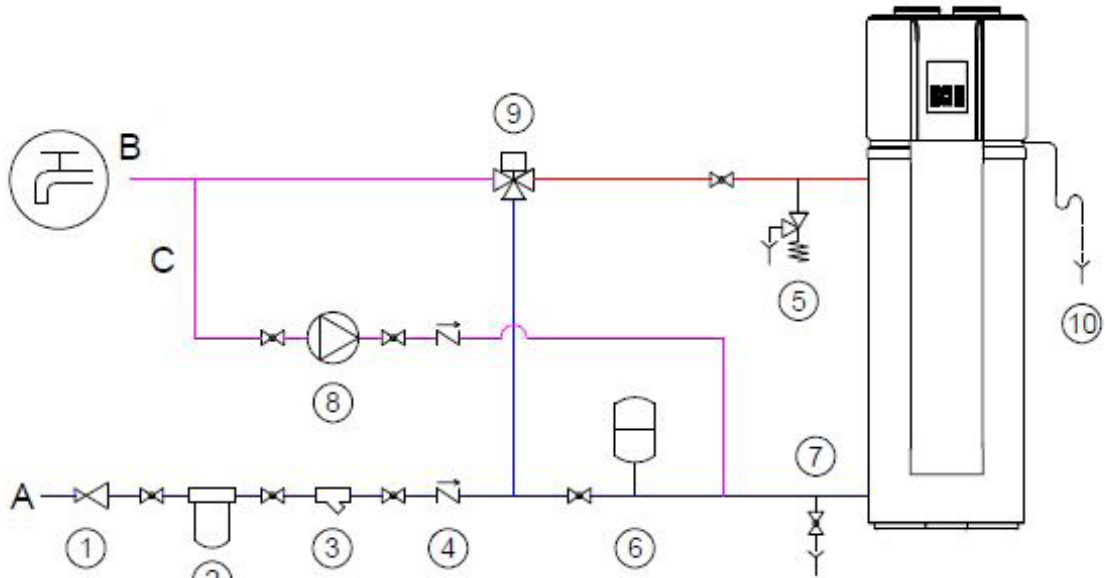

- 1. sure reducing valve
- 2. Water treatment devices (water softener, etc.)
- 3. Filter Y
- 4. Non-return valve
- 5. Domestic hot water safety valve with discharge
- 6. DHW expansion vessel
- 7. Storage drain
- 8. Hot water circulator (recirculation) with check valve
- 9. Mixing valve thermostatic
- 10. Condensate drain
- A - Aqueduct inlet
- B - DHW
- C - DHW recirculation

### Size 190S - 300S

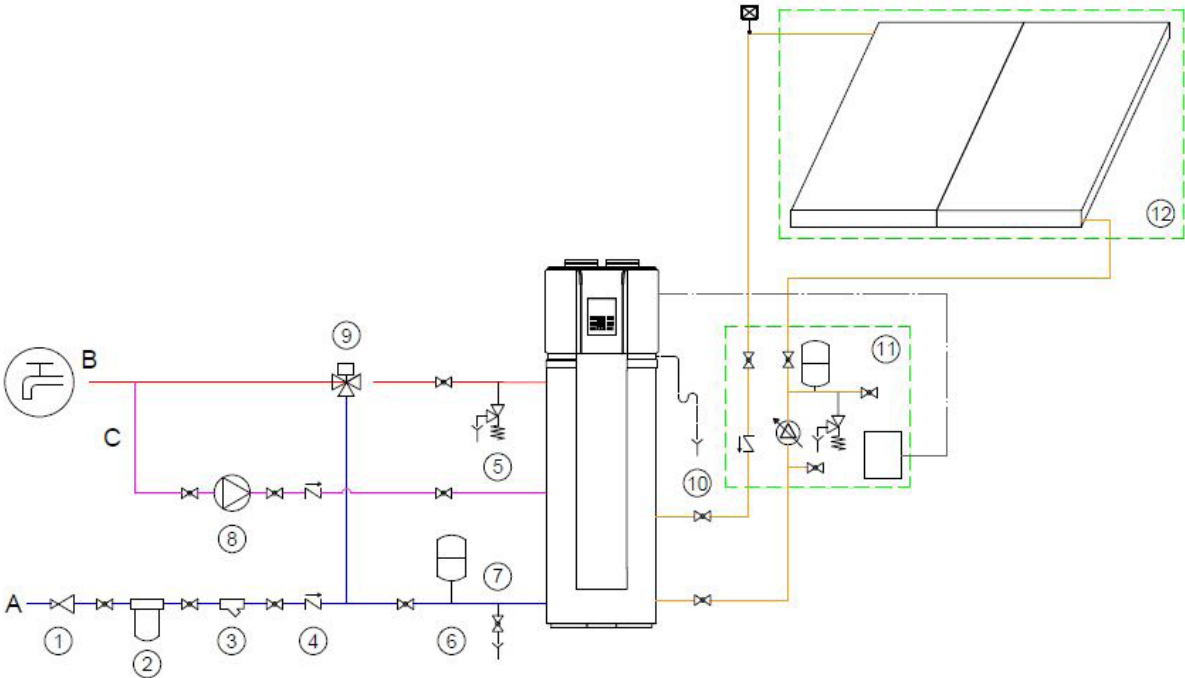

- 1. Pressure reducing valve
- 2. Water treatment devices (water softener, etc.)
- 3. Filter Y
- 4. Non-return valve
- 5. Domestic hot water safety valve with discharge
- 6. DHW expansion vessel
- 7. Storage drain
- 8. Hot water circulator (recirculation) with check valve
- 9. Mixing valve thermostatic
- 10. Condensate drain
- 11. Solar circulation unit (not supplied)
- 12. Solar panels (not supplied)
- A - Aqueduct inlet
- B - DHW
- C - DHW recirculation

# Aeraulic connections

The unit must be installed inside the building, preferably in a technical room or a laundry room or a garage. At any rate, it is always preferable to avoid installing the unit near bedrooms or in rooms that must be protected from noise. Outdoor installation is prohibited, as well as installation in places subject to external weather. Examples below refer to the SWH 190 version. For the SWH 300 version, the expulsion and intake connections are inverted.

## INTAKE AND EXPULSION DUCTS (recommended)

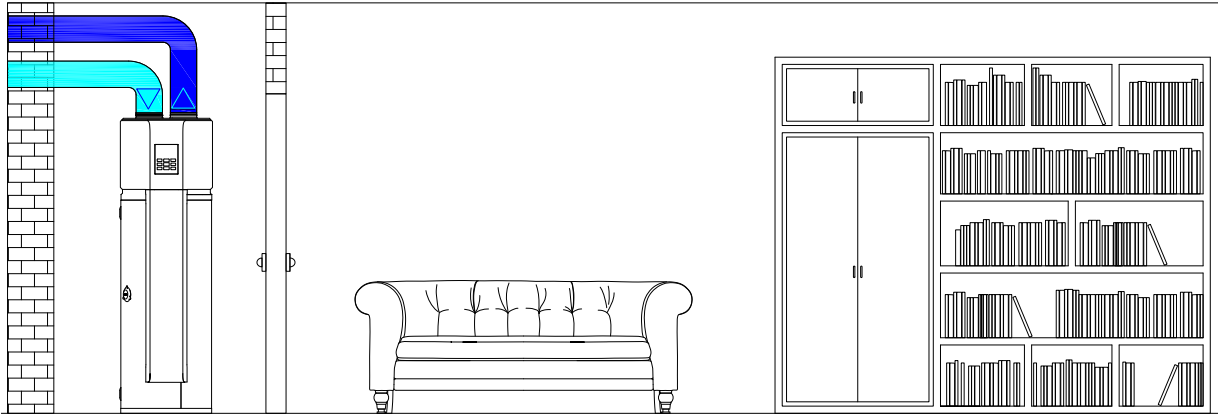

Channelling the intake and expulsion through ducts allows the unit to function with air taken from outside the house. Heat is extracted from the outdoor air, and used as a source for the heat pump. Later this same air is expelled outside the building. Therefore, unit operation does not cause an increase in heating requirements in the home. It is necessary to fit the system with correctly sized pipes in relation to the available pressure head supplied by the unit.

## INTAKE DUCTS (conditioned)

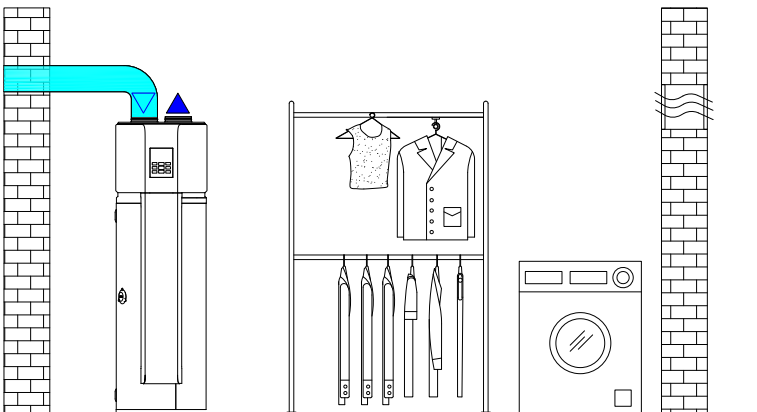

Installation with an intake duct and free expulsion is recommended if there is a desire to use the air expelled by the unit, cold dehumidified air (5-10°C colder than the intake air), to cool the room. The unit must be installed preferably in a room that does not require heating, because the unit releases cold air into the environment and it would increase the cost of heating that room. The unit must be installed in a room with a minimum volume greater than 15 m<sup>2</sup>. The expulsion air flow must be guaranteed and cannot be blocked. It is necessary that the vents be correctly sized.

## EXPULSION DUCTS (conditioned)

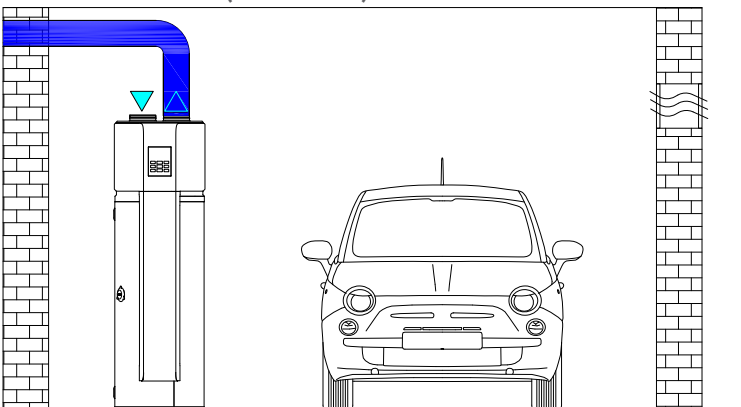

In this particular type of installation, the unit takes in air from the room where it is installed, extracts the heat and then expels that air outside the house. The unit must be installed in a room with suitable openings to allow the correct flow of air into the unit, which would prevent the air pressure in the room from falling. The unit must be installed in a room with a minimum volume greater than 15 m<sup>2</sup>.

# Data for the UNI/TS 11300 calculation

Producer declares that the data to be used for the calculation pursuant to UNI/TS 11300 part 4 of the efficiency of their heat pump are given in the following tables. The data given in this document may be updated without advance notice by the manufacturer when upgrading his product range.

## UNI/TS 11300 Part 4

SWH

DHW Data Capacity and COP full load		Te					
		Te	Tm	7	15	20	35
190	P. Heat $\Phi_{H,HP\ out}$ (W)	55°C	1362	1609	1755	2254	
	COP	55°C	3,22	3,66	3,93	4,86	
300	P. Heat $\Phi_{H,HP\ out}$ (W)	55°C	1814	2185	2365	3006	
	COP	55°C	3,49	4,04	4,30	5,03	

Terms and definitions

Tm = Supply Temperature

Te = Outdoor Air Temperature

## SMART GRID management - Photovoltaic

The unit is Smart Grid Ready certified and is equipped with logic for connection to devices that balance loads connected to the power grid and optimise overall power consumption.

Connection is optional and the function can be enabled at the keyboard and is linked to the SG ON/OFF input, which receives a status signal from the mains.

The unit is also able to automatically consume the excess energy produced by a photovoltaic system, using it to store free thermal energy in the DHW tank.

The function is enabled by default, it does not require any keyboard settings and is tied to the ON/OFF EVU input, which receives a signal from the energy meter indicating when excess free energy is available to the unit

The control logic of the two contacts is:

ENERGY COST	CONTACT		OPERATION
	SG	EVU	
Free	ON	ON	The set point is forced to TS = 70 °C The electric heater switches on if T5U < 65 °C and switches off if T5U ≥ 70 °C
Economical	OFF	ON	
Standard	OFF	OFF	Standard
Expensive	ON	OFF	Forced OFF The antilegionella cycle will be performed according to the mode setting

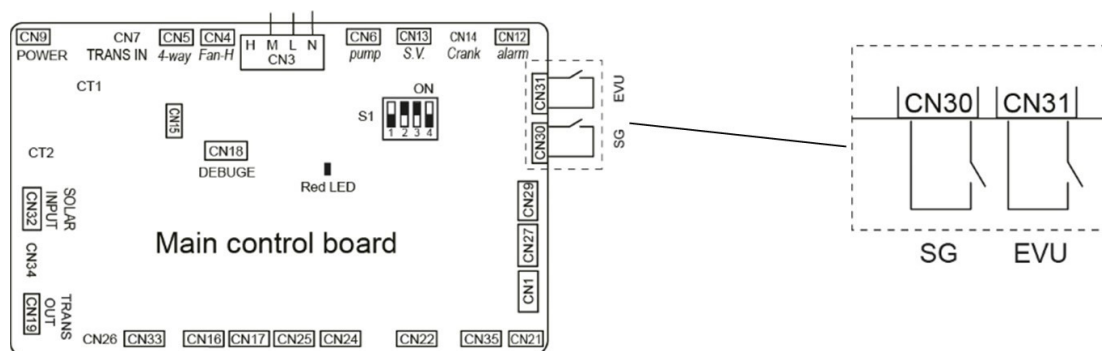

## Wi-Fi function and App control

The App MSmartLife is available for free for iOS and Android. The user is able to perform the following operations remotely:

- Turn the unit ON/OFF
- Set and display tank temperature
- Activate Boost function (E-Heater) for fast hot water production
- Schedule (daily, weekly, holiday mode)
- Activate anti-legionella function (Disinfect)
- Display smart grid connection

# Dimensional drawings

## SWH-190IRE2

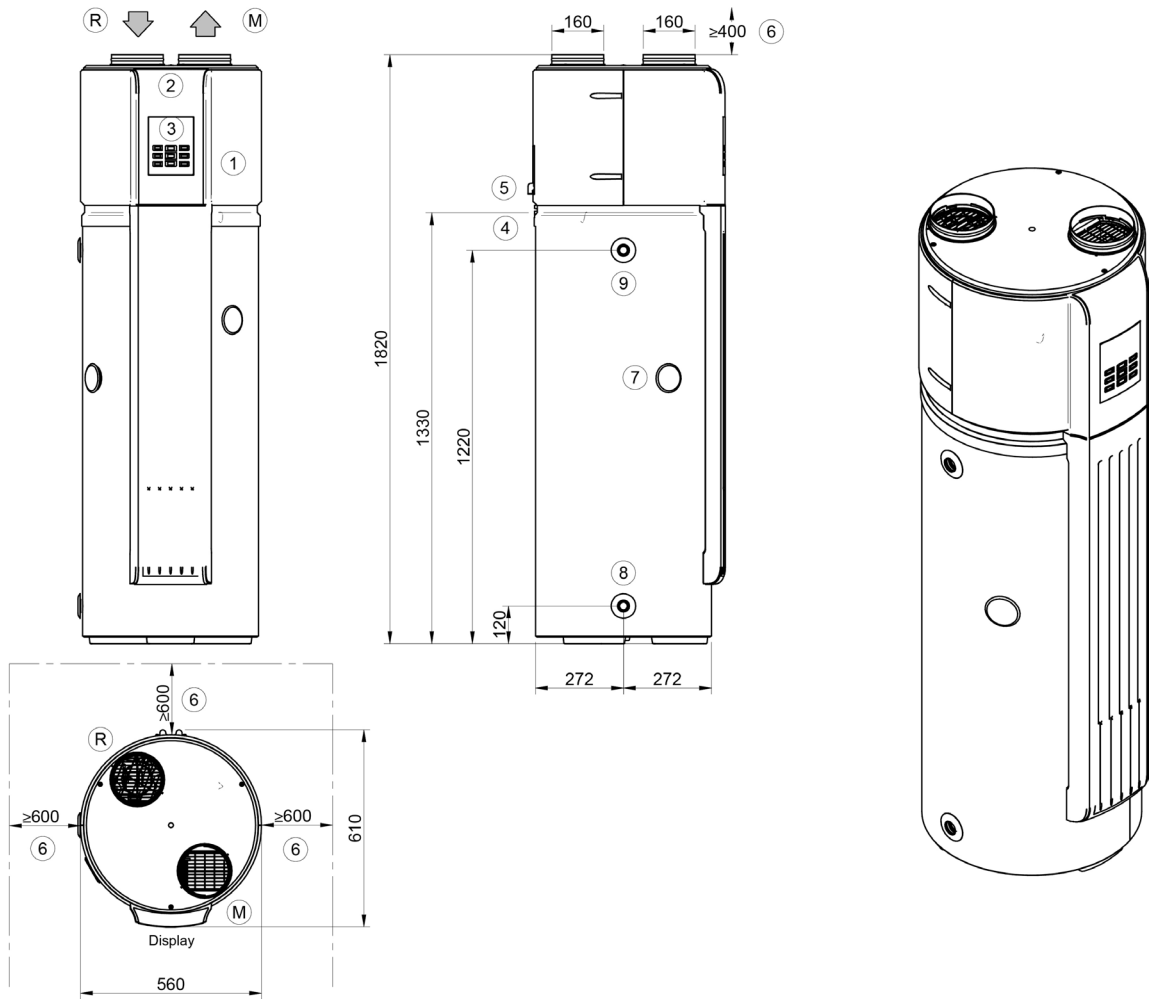

1. Compressor enclosure
2. Electrical panel
3. Control keypad
4. Power input
5. Condensate drain
6. Functional spaces

7. Anode rod
8. Water inlet 3/4" F
9. Water outlet 3/4" F
- (R) Air inlet
- (M) Air supply

### WEIGHT DISTRIBUTION

Operation weight	Kg	287
Shipping weight	Kg	126

Optional accessories may result in a substantial variation of the weight show in table



## SWH-190IRES2

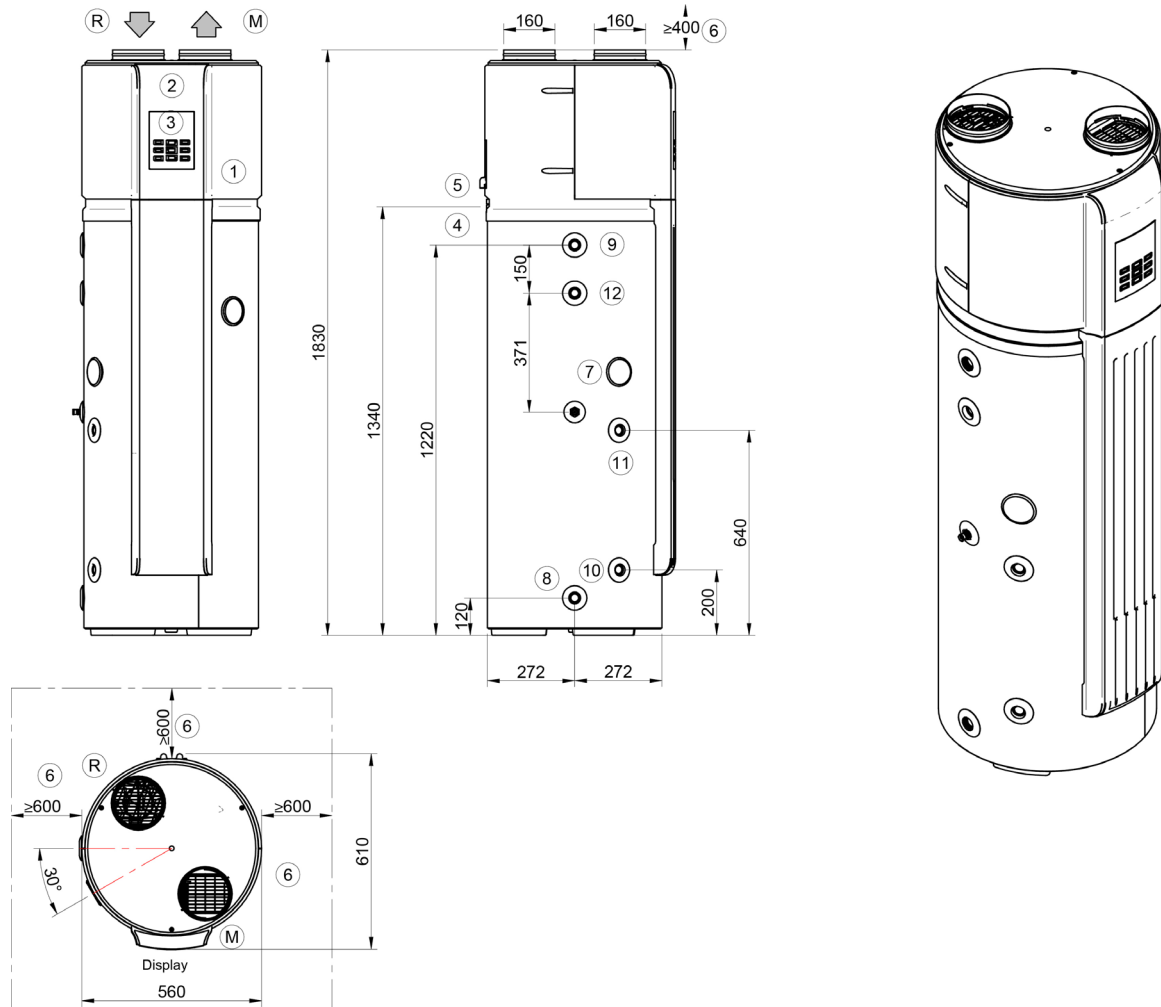

- |                         |                         |
|-------------------------|-------------------------|
| 1. Compressor enclosure | 8. Water inlet 3/4" F   |
| 2. Electrical panel     | 9. Water outlet 3/4" F  |
| 3. Control keypad       | 10. Solar inlet 3/4" F  |
| 4. Power input          | 11. Solar outlet 3/4" F |
| 5. Condensate drain     | 12. DHW recovery 3/4" F |
| 6. Functional spaces    | (R) Air inlet           |
| 7. Anode rod            | (M) Air supply          |

### WEIGHT DISTRIBUTION

Operation weight	Kg	310
Shipping weight	Kg	140

Optional accessories may result in a substantial variation of the weight show in table

# Dimensional drawings

## SWH-300IRE2

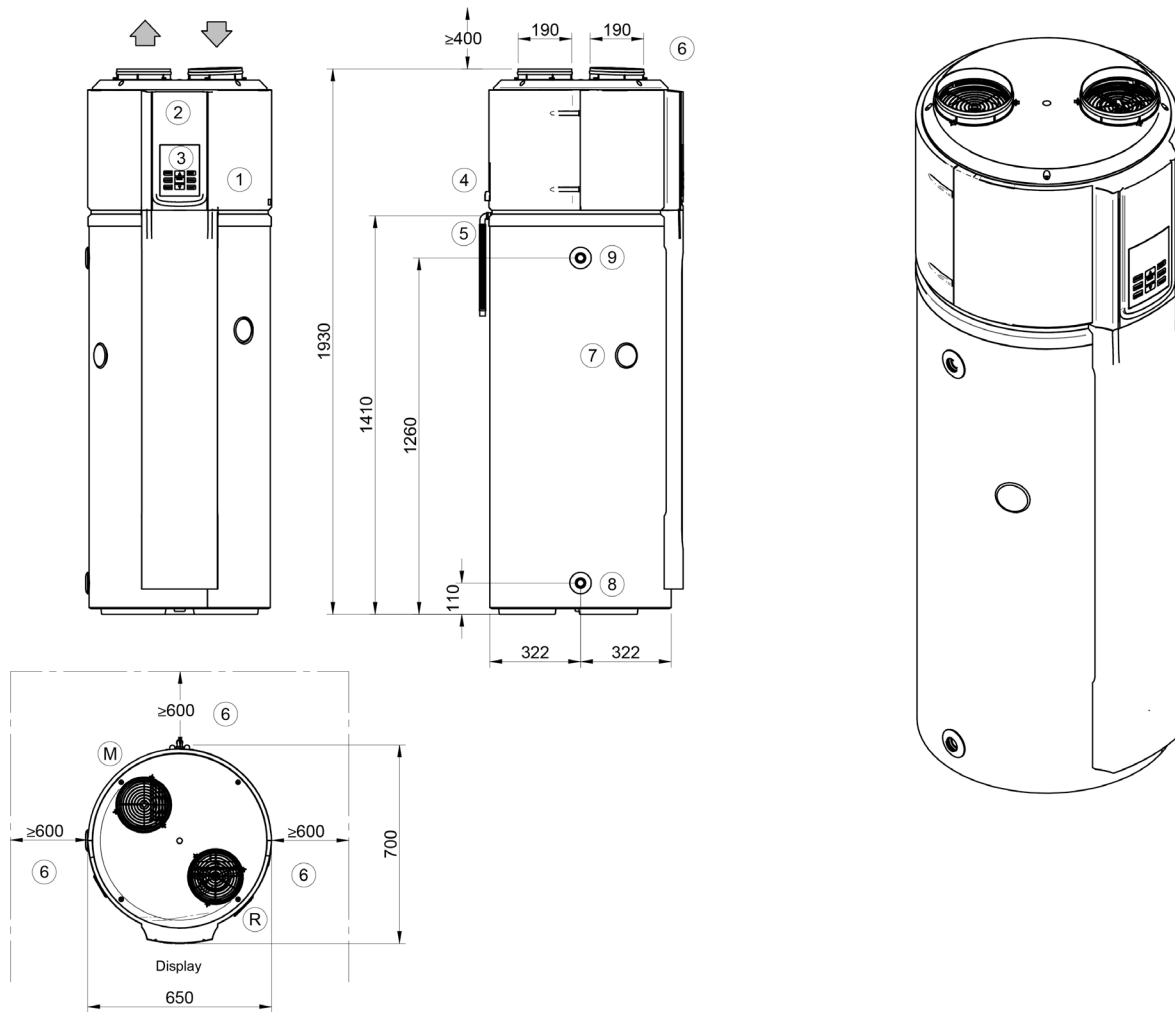

- |                         |                        |
|-------------------------|------------------------|
| 1. Compressor enclosure | 7. Anode rod           |
| 2. Electrical panel     | 8. Water inlet 3/4" F  |
| 3. Control keypad       | 9. Water outlet 3/4" F |
| 4. Power input          | (R) Air inlet          |
| 5. Condensate drain     | (M) Air supply         |
| 6. Functional spaces    |                        |

### WEIGHT DISTRIBUTION

Operation weight	Kg	412
Shipping weight	Kg	153

Optional accessories may result in a substantial variation of the weight show in table

## SWH-300IRES2

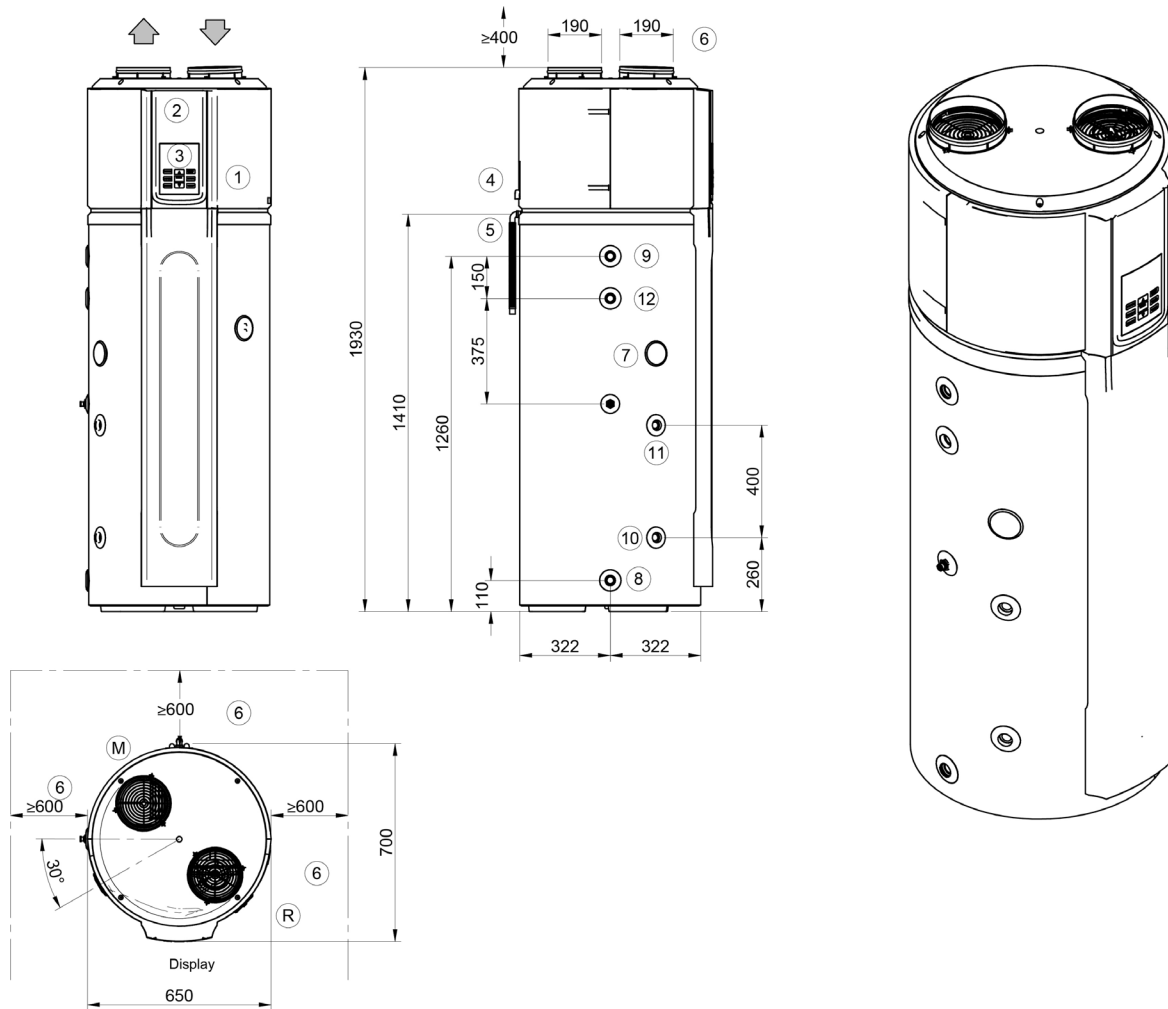

- |                         |                         |
|-------------------------|-------------------------|
| 1. Compressor enclosure | 8. Water inlet 3/4" F   |
| 2. Electrical panel     | 9. Water outlet 3/4" F  |
| 3. Control keypad       | 10. Solar inlet 3/4" F  |
| 4. Power input          | 11. Solar outlet 3/4" F |
| 5. Condensate drain     | 12. DHW recovery 3/4" F |
| 6. Functional spaces    | (R) Air inlet           |
| 7. Anode rod            | (M) Air supply          |

### WEIGHT DISTRIBUTION

Operation weight	Kg	434
Shipping weight	Kg	172

Optional accessories may result in a substantial variation of the weight show in table

**EN**

For downloading manual for this product, please enter the model name at this link:

**CZ**

Pro stažení manuálu k tomuto produktu zadejte modelové označení do následujícího odkazu:

**SK**

Pre stiahnutie manuálu k tomuto produktu zadajte modelové označenie do nasledujúceho odkazu:

**DE**

Um das Handbuch für dieses Produkt herunterzuladen, geben Sie bitte den Modellnamen für diesen Link ein:

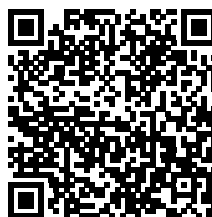
**HR**

Za preuzimanje priručnika za ovaj proizvod unesite naziv modela na ovu vezu:

**HU**

Termék kézikönyvének letöltéséhez írja be a modell megnevezését az alábbi linkre:

**SL**

Za prenos navodil za uporabo tega izdelka, vnesite ime modela na tej povezavi:

**RU**

Чтобы загрузить руководство для этого продукта, введите обозначение модели по следующей ссылке:

**IT**

Per scaricare il manuale di questo prodotto, inserisci il nome del modello a questo link:

**ES**

Para descargar el manual de este producto, ingrese la designación del modelo en el siguiente enlace:



## NOTE CONCERNING PROTECTION OF ENVIRONMENT

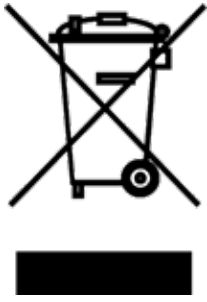

This product must not be disposed of via normal household waste after its service life, but must be taken to a collection station for the recycling of electrical and electronic devices. The symbol on the product, the operating instructions or the packaging indicate such disposal procedures. The materials are recyclable in accordance with their respective symbols. By means of re-use, material recycling or any other form of recycling old appliances you are making an important contribution to the protection of our environment. Please ask your local council where your nearest disposal station is located.

## INFORMATION CONCERNING USED REFRIGERANT MEDIUM

This unit is containing fluorinated gases included in the Kyoto protocol. The maintenance and the liquidation must be carried out by qualified personnel.

Type of refrigerant: R134A

The quantity of the refrigerant: please see the unit label.

The value GWP: 1430 (1 kg R134A = 1,430 t CO<sub>2</sub> eq)

GWP = Global Warming Potential

In case of quality problem or other please contact your local supplier or authorized service center.

**Emergency number: 112**

## PRODUCER

SINCLAIR CORPORATION Ltd.

16 Great Queen Street

WC2B 5AH London

United Kingdom

[www.sinclair-world.com](http://www.sinclair-world.com)

This product was manufactured in China (Made in China).

## REPRESENTATIVE

SINCLAIR Global Group s.r.o.

Purkynova 45

612 00 Brno

Czech Republic

## TECHNICAL SUPPORT

SINCLAIR Global Group s.r.o.

Purkynova 45

612 00 Brno

Czech Republic

Tel.: +420 800 100 285 | Fax: +420 541 590 124

[www.sinclair-solutions.com](http://www.sinclair-solutions.com) | [info@sinclair-solutions.com](mailto:info@sinclair-solutions.com)







