

Data Sheet

Strainer housing Type **FIA**

With butt-weld connection F
Design makes the strainer easy to install



FIA strainers are a range of angleway and straightway strainers, which are carefully designed to give favourable flow conditions. The design makes the strainer easy to install, and ensures quick strainer inspection and cleaning.

FIA strainers are used ahead of automatic controls, pumps, compressors etc., for initial plant start-up and where permanent filtration of the refrigerant is required. The strainer reduces the risk of undesirable system breakdowns and reduces wear and tear on plant components.

FIA strainers are equipped with a screen mesh of stainless steel, available in sizes 100, 150, 250 and 500 μ (microns), (US 150, 100, 72, 38*).

* Mesh is the number of threads per inch. μ (microns) is the distance between two threads ($1\mu = 1/1000$ mm).

Features

- Modular Concept:
 - Each valve housing is available with butt-weld F connection and with several different sizes.
 - Possible to convert FIA strainers to any other product in the SVL family (Shut-off valve, regulating valve, check & stop valve or check valve) just by replacing the complete top part.
- Fast and easy overhaul service. It is easy to replace the top part and no welding is needed.
- Filter net of stainless steel mounted direct without extra gaskets means easy servicing.
- Two types of strainer inserts are available:
 - A plain insert of stainless steel.
 - A pleated insert (DN 15-200) with extra large surface, which ensures long intervals between cleaning and low pressure drop.
- FIA 15-40 (½ – 1 ½ in.): A special insert (50µ) can be used in combination with a standard version when cleaning a plant during commissioning.
- FIA 50-200 (2 - 8 in.): A large capacity filter bag (50µ) can be inserted for cleaning plant during commissioning.
- FIA 65-200 (2½ - 8 in.) can be equipped with a magnetic insert for detention of iron particles and other magnetic particles.
- Each strainer clearly marked with type, size and performance range.
- Housing and bonnet of low temperature steel in accordance with the requirements of the Pressure Equipment Directive and those of other international classification authorities.
- Classification: DNV, CRN, BV, EAC etc. To get an updated list of certification on the products please contact your local Danfoss Sales Company.

Media

Refrigerants

Applicable to HCFC, HFC, R717 (Ammonia) and R744 (CO₂). For further information refer to the product instruction for FIA.

New refrigerants

Danfoss products are continually evaluated for use with new refrigerants depending on market requirements.

When a refrigerant is approved for use by Danfoss, it is added to the relevant portfolio, and the R number of the refrigerant (e.g. R513A) will be added to the technical data of the code number. Therefore, products for specific refrigerants are best checked at store.danfoss.com/en/, or by contacting your local Danfoss representative.

Product specification

Pressure and temperature data

Table 1: Pressure and temperature data

Features	Description
Temperature range	-60 °C/+150 °C (-76 °F/+302 °F).
Max. working pressure	52 bar(g) (754 psig) for DN15 to DN 125
	25 bar(g) (362 psig) for DN 150 to DN 200

For more detail on pressure and temperature range; see [Table 2](#)

Figure 1: Pressure/Temperature range chart for SVL product range with butt-weld connection F

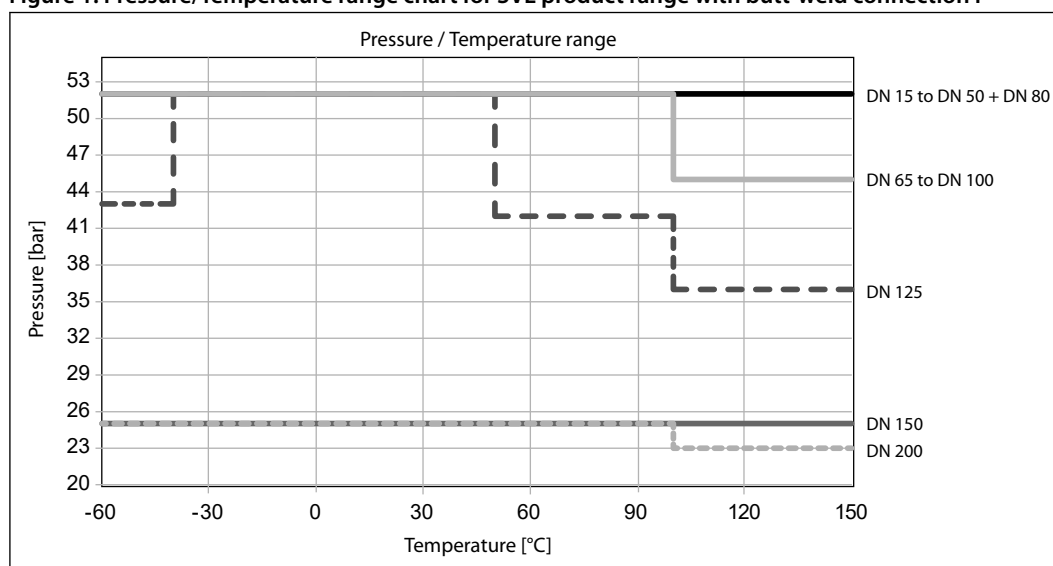

For valve sizes DN 15 to DN 50 and DN 80:
52 bar(g) (754 psig) at -60 °C to +150 °C (-76 °F to +302 °F).

For valve sizes DN 65 and DN100:
52 bar(g) (754 psig) at -60 °C to +100 °C (-76 °FF to +212 °F),
45 bar(g) (652 psig) at +100 °C to +150 °C (+212 °F to +302 °F).

For valve size DN 125:
52 bar(g) (754 psig) at -40 °C to +50 °C (-40 °F to +122 °F)
43 bar(g) (623 psig) at -60 °C to -40 °C (- 76 °F to -40 °F),
42 bar(g) (609 psig) at +50 °C to +100 °C (+122 °F to +212 °F),
36 bar(g) (522 psig) at +100 °C to+150 °C (+212 °F to +302 °F).

For valve size DN 150:
25 bar(g) (362 psig) at -60 °C to +150 °C (-76 °F to +302 °F).

For valve size DN 200:
25 bar(g) (362 psig) at -60 °C to +100 °C (-76 °F to +212 °F),
23 bar(g) (333 psig) at +100 °C to +150 °C (+212 °F to +302 °F).

SVL housings with other connection types (DIN, ANSI, SOC and thread) are approved for a maximum working pressure of 52 bar(g) (754 psig) at -60 °C to +150 °C (-76 °F to +302 °F) for all sizes.

The reduced pressure in some of the SVL housings with connection type F is caused by the welding onto stainless steel pipes with reduced pipe size.

Strainer housing, type FIA with butt-weld connection F

Table 2: Pressure/Temperature range chart for SVL product range with butt-weld connection F

Size [DN]	SVA-S				SVA-L				SCA-X	CHV-X	FIA		REG-SA		REG-SB	
	ANG		STR		ANG		STR		ANG	ANG	ANG	STR	ANG	STR	ANG	STR
	H-WHEEL	CAP	H-WHEEL	CAP	H-WHEEL	CAP	H-WHEEL	CAP	CAP	CAP	CAP	CAP	CAP	CAP	CAP	CAP
15	X	X	X	X	X	X	X	X	X	X	X	X	X	X	X	X
20	X	X	X	X	X	X	X	X	X	X	X	X	X	X	X	X
25	X	X	X	X	X	X	X	X	X	X	X	X	X	X	X	X
32	X	X	X	X	X	X	X	X	X	X	X	X	X	X	X	X
40	X	X	X	X	X	X	X	X	X	X	X	X	X	X	X	X
50	X	X	X	X					X	X	X	X			X	
65	X	X	X	X					X	X	X	X			X	
80	X	X	X	X					X	X	X	X				
100	X	X	X	X					X	X	X	X				
125	X	X	X	X					X	X	X	X				
150	X	X	X	X							X	X				
200	X	X	X	X							X	X				

X = Available

Connection

Figure 2: F connection

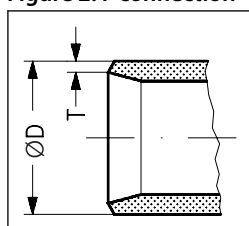

Table 3: Dimensions

Size	Size	øD	T	øD	T
mm	in.	mm	mm	in.	in.
15	½	21.3	2	0.839	0.079
20	¾	26.9	2	1.059	0.079
25	1	33.7	2	1.327	0.079
32	1¼	42.4	2	1.669	0.079
40	1½	48.3	2	1.902	0.079
50	2	60.3	2	2.37	0.079
65	2½	76.1	2	3	0.079
80	3	90.9	3	3.579	0.118
100	4	116.3	3	4.579	0.118
125	5	141.7	3	5.579	0.118
150	6	170.3	3	6.705	0.118
200	8	221.1	33	8.705	0.118

Available with the following connections:

- Butt-weld connection "F"
- DN 15 to 65 size: 2mm thick
- DN 80 -200 size: 3 mm thick

Installation/Maintenance

The strainer is designed to resist high internal pressures. However, the piping system in general should be designed to avoid liquid traps and reduce the risk of hydraulic pressure caused by thermal expansion. Install the strainer with the cover in downward position.

Strainer housing, type FIA with butt-weld connection F

Danfoss recommends replacement/cleaning of the strainer when the differential pressure loss >0.5 bar (7.3 psi) in the liquid line and >0.05 bar (0.7 psi) in the suction line. The max. permissible differential pressure is 1 bar (15 psi). For further information refer to installation instruction for FIA.

Design

Figure 3: Example of marking ring, FIA

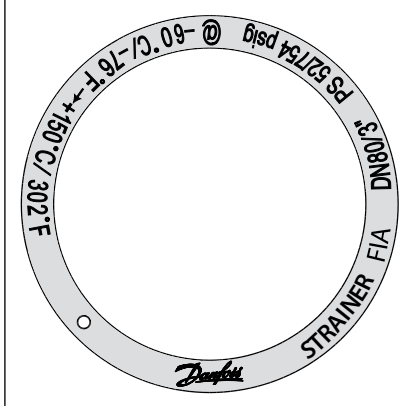

Strainer Insert

A filter grid and filter net of stainless steel ensure long element life. The filter net offers a very high degree of cleanability.

Housing

The strainer housing is made of special, cold resistant steel.

Selection of strainer size

Definition

Mesh is the number of threads per inch. μ (microns) is the distance between two threads ($1\mu = 1/1000$ mm).

The mesh aperture size of the strainer must satisfy the requirements stated by the suppliers of the equipment to be protected. The following recommendations of aperture size apply in general to refrigeration installations:

All lines

First start up : 50 μ

(Use strainer element with removable insert for FIA DN15-40 or separate filter bag for FIA DN 50-200. 50 μ insert should normally be removed after the first 24 hours of operation)

Liquid Lines

Ahead of pumps: 500 μ [38 mesh]

After pumps: 150 μ [100 mesh] / 250 μ [72 mesh]

In front of AKVA valves: 100 μ [150 mesh]

Protection of automatic regulation equipment

Generally : 150 μ [100 mesh] / 250 μ [72 mesh] Sensitive equipment
e.g. suction regulators with low temperature : 250 μ [72 mesh]

Suction Lines

Ahead of screw compressor : 250 μ [72 mesh]

Ahead of piston compressor : 150 μ [100 mesh]

Strainer housing, type FIA with butt-weld connection F

Table 4: Flow coefficient (DIN/ANSI)

Connection size (DN)	μ	mesh	wire	wire	free space	screen area			
			mm	in.	%	Plain elements		Pleated elements	
						cm ²	in ²	cm ²	in ²
15 - 20 (1/2"-3/4")	100		0.068	0.003	35	25	3.9	45	7
	150	100	0.1	0.004	36	25	3.9	45	7
	250	72	0.1	0.004	51	25	3.9	45	7
	500	38	0.16	0.006	57.6	25	3.9	45	7
25 - 40 (1" - 1 1/2")	100		0.068	0.003	35	71	11	160	25
	150	100	0.1	0.004	36	71	11	160	25
	250	72	0.1	0.004	51	71	11	160	25
	500	38	0.16	0.006	57.6	71	11	160	25
50 (2")	100		0.068	0.003	35	71	11	200	31.2
	150	100	0.1	0.004	36	87	13.5	200	31.2
	250	72	0.1	0.004	51	87	13.5	200	31.2
	500	38	0.16	0.006	57.6	87	13.5	200	31.2
65 (2 1/2")	150	100	0.1	0.004	36	127	19.7	305	47.6
	250	72	0.1	0.004	51	127	19.7	305	47.6
	500	38	0.16	0.006	57.6	127	19.7	305	47.6
80 (3")	150	100	0.1	0.004	36	205	31.8	450	70.2
	250	72	0.1	0.004	51	205	31.8	450	70.2
	500	38	0.16	0.006	57.6	205	31.8	450	70.2
100 (4")	150	100	0.1	0.004	36	370	57.4	790	123.2
	250	72	0.1	0.004	51	370	57.4	790	123.2
	500	38	0.16	0.006	57.6	370	57.4	790	123.2
125 (5")	150	100	0.1	0.004	36	510	79.1	1105	172.4
	250	72	0.1	0.004	51	510	79.1	1105	172.4
	500	38	0.16	0.006	57.6	510	79.1	1105	172.4
150 (6")	150	100	0.1	0.004	36	726	112.5	1600	249.6
	250	72	0.1	0.004	51	726	112.5	1600	249.6
	500	38	0.16	0.006	57.6	726	112.5	1600	249.6
200 (8")	150	100	0.1	0.004	36	1315	203.8		
	250	72	0.1	0.004	51	1315	203.8		
	500	38	0.16	0.006	57.6	1315	203.8		

Table 5: k_v values

DN	FIA angle - plain filter net				FIA angle - pleated filter net		
	μ100	μ150	μ250	μ500	μ150	μ250	μ500
15	3.3	3.4	3.5	3.7	4.2		
20	6.9	7.1	7.3	7.7	8.8		
25	13.8	14	14.5	15.2	17.2	17.9	
32	23	23.8	24.7	25.5	29.2	30.5	
40	25.1	25.5	26.4	28.1	31.4	32.6	
50	45.1	45.9	47.6	50.2	56.7	58.8	62
65		56.1	57.8	60.4	69.3	71.4	74.6
80		104.6	108	113.1	129.2	133.4	139.7
100		162.4	167.5	176	200.6	206.9	217.4
125		275.4	283.9	298.4	340.2	350.7	368.6
150		362.1	373.2	391.9	447.3		
200		572.9	590.8	620.5			

Table 6: k_v values

DN	FIA straight - plain filter net				FIA straight - pleated filter net		
	μ100	μ150	μ250	μ500	ν150	μ250	μ500
15	2.5	2.6	2.7	2.8	3.3		
20	5.3	5.4	5.6	5.9	6.9		
25	10.5	10.7	11.1	11.6	13.8	14.5	
32	17.6	18.2	18.9	19.5	23.9	24.7	
40	19.2	19.5	20.2	21.5	25.5	26.4	

Strainer housing, type FIA with butt-weld connection F

DN	FIA straight - plain filter net				FIA straight - pleated filter net		
	μ100	μ150	μ250	μ500	v150	μ250	μ500
50	34.5	35.1	36.4	38.4	45.9	47.6	50.2
65		42.9	44.2	46.2	56.1	57.8	60.4
80		80	82.6	86.5	104.6	108	113.1
100		124.2	128.1	134.6	162.4	167.5	176
125		210.6	217.1	228.2	275.4	283.9	298.4
150		276.9	285.4	299.7	362.1		
200		438.1	451.8	474.5			

Material specification

Table 7: FIA 15 - 40 (1/2 in. - 1 1/2 in.)

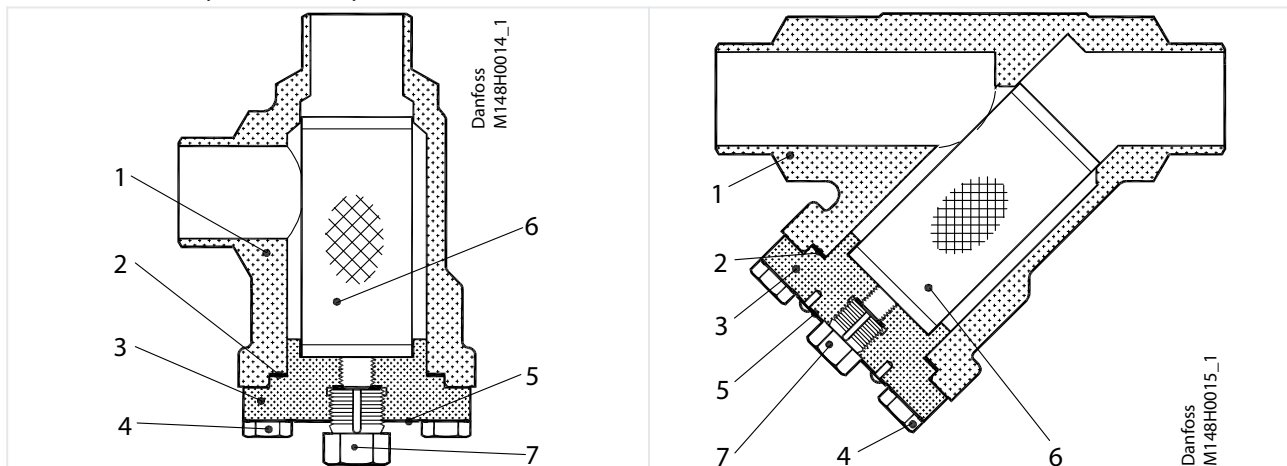
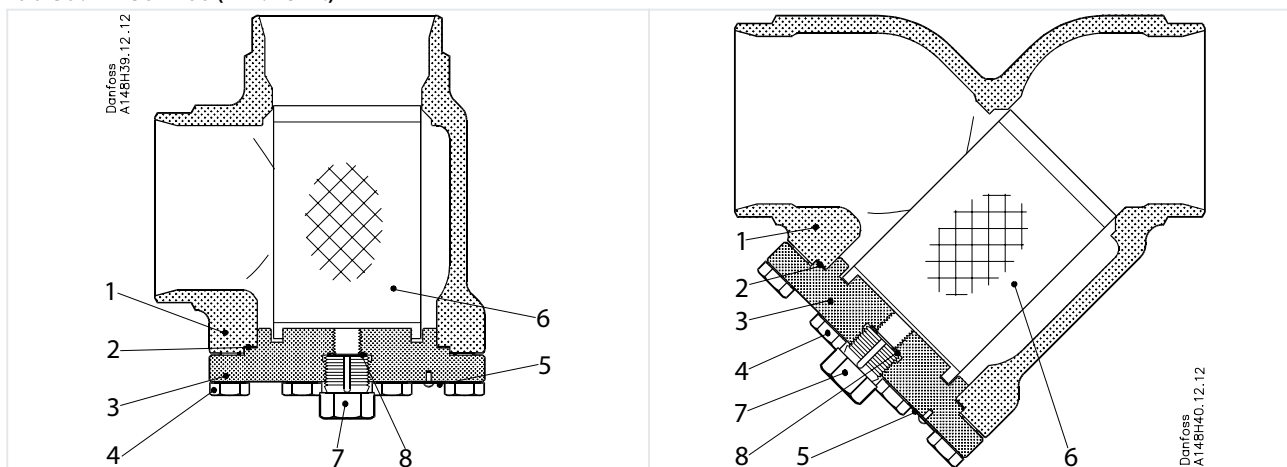

Table 8: FIA 15-40 (1/2 in. - 1 1/2 in.)

No.	Part	Material	DIN	ISO	ASTM
1	Housing	Steel	G20Mn5QT, 10213-3		LCC, A352
			P285QH+QT, 10222-4		LF2, A350
2	Gasket	Fibre, Non-asbestos			
3	Cover	Steel	P285QH EN10222-4		LF2, A350
			P275NL1 or 2 EN10028-3		A, A662
4	Bolts	Stainless steel	A2-70	A2-70	Type 308
5	Marking label	Aluminium			
6	Strainer element	Stainless steel			

Table 9: FIA 50 - 200 (2 in. - 8 in.)



Strainer housing, type FIA with butt-weld connection F

Table 10: FIA 50-200 (2 in. - 8 in.)

No.	Part	Material	DIN	ISO	ASTM
1	Housing	Steel	G20Mn5QT, 10213-3		LCC, A352
			P285QH+QT, 10222-4		LF2, A350
2	Gasket	Fibre, Non-asbestos			
3	Cover	Steel	P285QH EN10222-4		LF2, A350
			P275NL1 or 2 EN10028-3		A, A662
4	Bolts	Stainless steel	A2-70	A2-70	Type 308
5	Marking label	Aluminium			
6	Strainer element	Stainless steel			
7	Pressure relief (screw)	Stainless steel			
8 ⁽¹⁾	Packing washer	Aluminium			

⁽¹⁾ pos 8 used in FIA 50-200

Dimensions and weights

Table 11: FIA 15 - 65

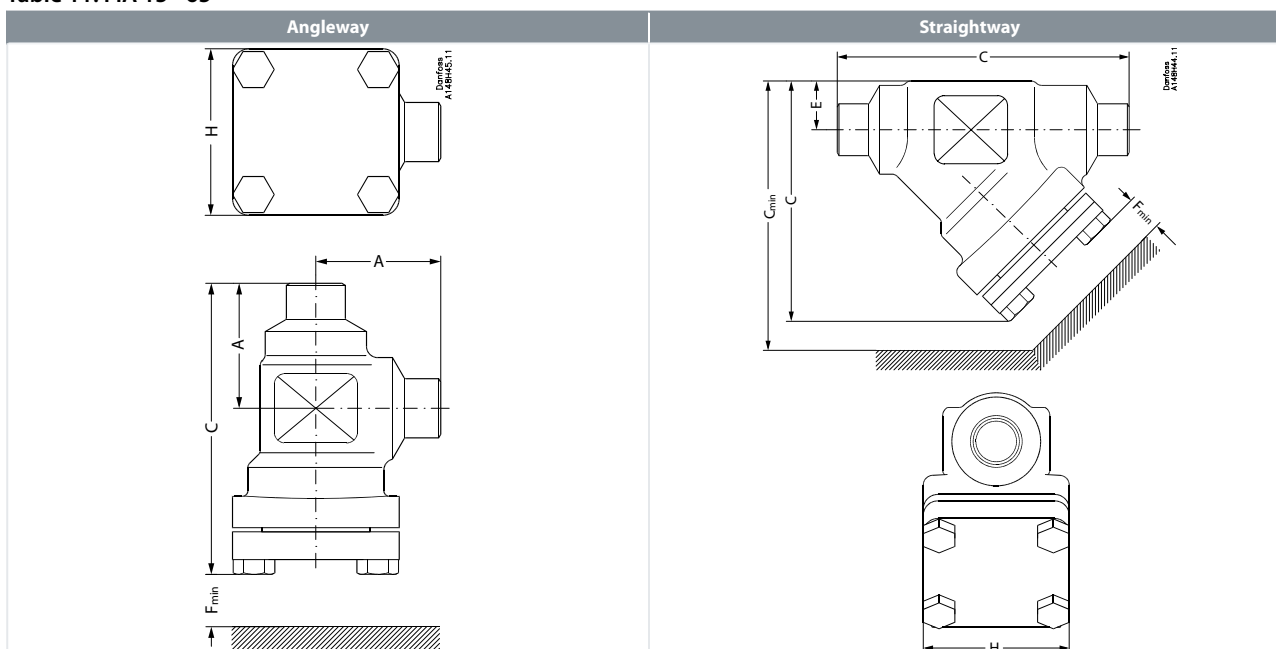

Table 12: Angleway

Strainer size		A	C	H	F _{min.}	Weight
FIA 15-20 (1/2" - 3/4")	mm	45	105	60	68	1.1 kg
	in.	1.77	4.13	2.36	2.68	2.4 lbs
FIA 25-40 (1" - 1 1/2")	mm	55	132	70	95	1.7 kg
	in.	2.17	5.20	2.76	3.74	3.7 lbs
FIA 50 (2")	mm	60	132	77	92	2.8 kg
	in.	2.36	5.20	3.03	3.62	6.2 lbs
FIA 65 (2 1/2")	mm	70	152	90	107	3.8 kg
	in.	2.76	5.98	3.54	4.21	8.4 lbs

Table 13: Straightway

Strainer size		A	C	C _{min.}	H	E	F _{min.}	Weight
FIA 15-20 (1/2" - 3/4")	mm	120	99	133	60	20	68	1.4 kg
	in.	4.72	3.9	5.24	2.36	0.79	2.68	3.1 lbs
FIA 25-40 (1" - 1 1/2")	mm	155	129	177	70	26	95	2.4 kg
	in.	6.1	5.08	6.97	2.76	1.02	3.74	5.3 lbs

Strainer housing, type FIA with butt-weld connection F

Strainer size		A	C	C _{min.}	H	E	F _{min.}	Weight
FIA 50 (2")	mm	148	138	184	77	32	92	3.5 kg
	in.	5.83	5.43	7.24	3.03	1.26	3.62	7.7 lbs
FIA 65 (2½")	mm	176	165	219	90	40	107	5.3 kg
	in.	6.93	6.5	8.62	3.54	1.57	4.21	11.7 lbs

Table 14: FIA 80 - 200

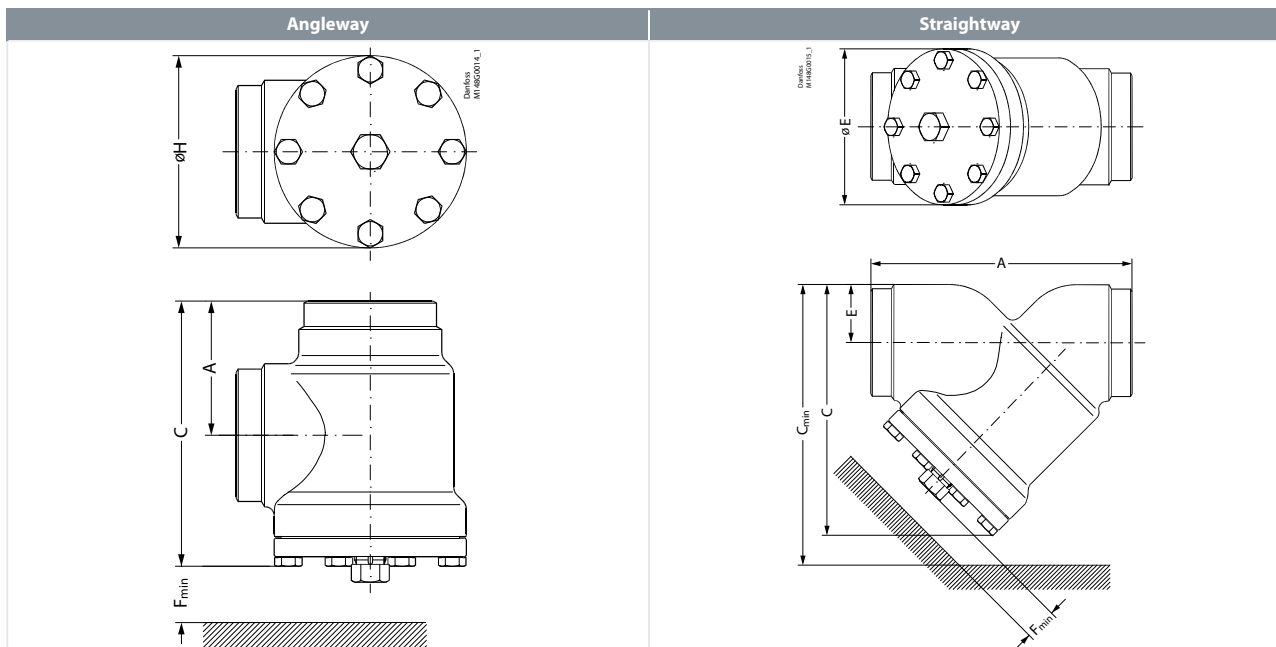

Table 15: Angleway

Strainer size		A	C	ØH	F _{min.}	Weight
FIA 80 (3")	mm	90	189	129	133	7.3 kg
	in.	3.54	7.44	5.08	5.24	16.1 lbs
FIA 100 (4")	mm	106	223	156	163	11.9 kg
	in.	4.17	8.78	6.14	6.42	26.2 lbs
FIA 125 (5")	mm	128	268	192	190	21.2 kg
	in.	5.04	10.6	7.56	7.48	46.7 lbs
FIA 150 (6")	mm	145	303	219	223	30.5 kg
	in.	5.71	11.93	8.62	8.78	67.2 lbs
FIA 200 (8")	mm	180	372	276	280	68 kg
	in.	7.09	14.65	10.87	11.02	150 lbs

Table 16: Straightway

Strainer size		A	C	C _{min.}	H	ØE	F _{min.}	Weight
FIA 80 (3")	mm	216	204	271	129	48	133	8.6 kg
	in.	8.5	8.03	10.67	5.08	1.89	5.24	19 lbs
FIA 100 (4")	mm	264	256	337	156	60	163	14.9 kg
	in.	10.39	10.08	13.27	6.14	2.36	6.42	32.8 lbs
FIA 125 (5")	mm	322	313	408	192	74	190	26.9 kg
	in.	12.68	12.32	16.06	7.56	2.91	7.48	59.3 lbs
FIA 150 (6")	mm	370	370	482	219	91	223	51 kg
	in.	14.57	14.57	18.98	8.62	3.58	8.78	112 lbs
FIA 200 (8")	mm	464	465	605	276	117	280	95 kg
	in.	18.27	18.31	23.82	10.87	4.61	11.02	209 lbs

NOTE:

Weight shown in tables 12-16 is approximated.

Ordering

The table below is used to identify the strainer required. Please note that you have to order **FIA strainer without element, a strainer element and accessories.**

Example:

FIA 150 F ANG + FIA-X 150 150µ Strainer
Element + Filter Bag = 148B6442 + 148H3134 +148H3155

Table 17: Butt-weld F connection - Angleway

Size		Type	FIA Without Strainer Element	Strainer Element 100µ 150 mesh	Strainer Element 150µ 100 mesh	Strainer Element 250µ 72 mesh	Strainer Element 500µ 38 mesh	Pleated Strainer element 150µ 100 mesh	Pleated Strainer element 250µ 72 mesh	Pleated Strainer element 500µ 38 mesh
mm	in.									
150	6	FIA 150 F ANG	148B6442	-	148H3134	148H3142	148H3148	148H3226	-	-
200	8	FIA 200 F ANG	148B6443	-	148H3135	148H3143	148H3149	148H3297	-	-

Table 18: Butt-weld F connection - Straightway

Size		Type	FIA Without Strainer Element	Strainer Element 100µ 150 mesh	Strainer Element 150µ 100 mesh	Strainer Element 250µ 72 mesh	Strainer Element 500µ 38 mesh	Pleated Strainer element 150µ 100 mesh	Pleated Strainer element 250µ 72 mesh	Pleated Strainer element 500µ 38 mesh
mm	in.									
150	6	FIA 150 F STR	148B6444	-	148H3134	148H3142	148H3148	148H3226	-	-
200	8	FIA 200 F STR	148B6445	-	148H3135	148H3143	148H3149	148H3297	-	-

F	Butt-weld F
ANG	Angleway
STR	Straightway

Table 19: Accessories

Part	Accessory for	Code number
Magnet insert	FIA 65-100	148H3447
	FIA 125-200	148H3448
Strainer element 150µ with removable element 50µ for the first start up	FIA 15-20	148H3301
	FIA 25-40	148H3302
Filter bag	FIA 50	148H3150
	FIA 65	148H3151
	FIA 80	148H3152
	FIA 100	148H3153
	FIA 125	148H3154
	FIA 150	148H3155
	FIA 200	148H3156
Purge valve complete	FIA 50-300	148B3745
Blind nut with gasket		148H3450
Special strainer element permanent 50µ for CO ₂ applications	FIA 15-20	032F9113 ⁽¹⁾

⁽¹⁾ The 2 O-rings which come together with the strainer element should not be used for strainer installation in the FIA 15-20.

NOTE:

Please note that the 50µ strainer element can be filled up quite fast, so it is recommended to inspect and clean the strainer element at regular intervals based on experience at the installation site.

Strainer housing, type FIA with butt-weld connection F

Ordering FIA strainers from the parts programme

Example (select from [Table 21](#) and [Table 23](#))

Figure 4: FIA strainers from the parts programme

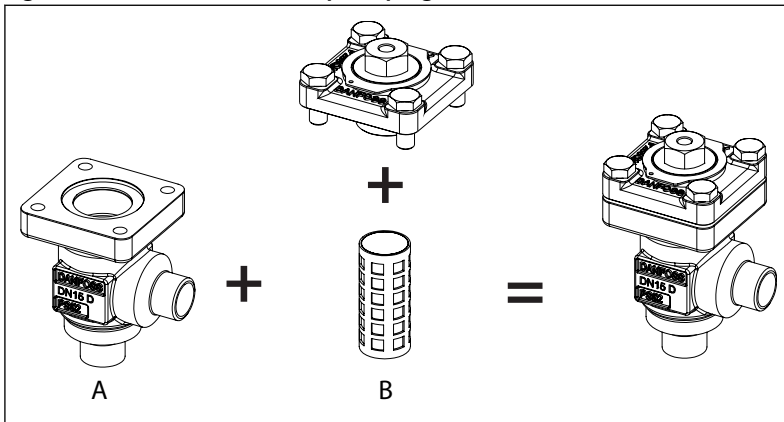

A Strainer Housing, size 25 (1 in.), butt weld F, angleway, 148B6416, [Table 21](#)

B Top part, FIA, size 25 (1 in.) 148B5484 + Strainer insert, 250µ, 72 mesh 148H3127 [Table 23](#)

Table 20: FIA strainer valve housings w/different connections

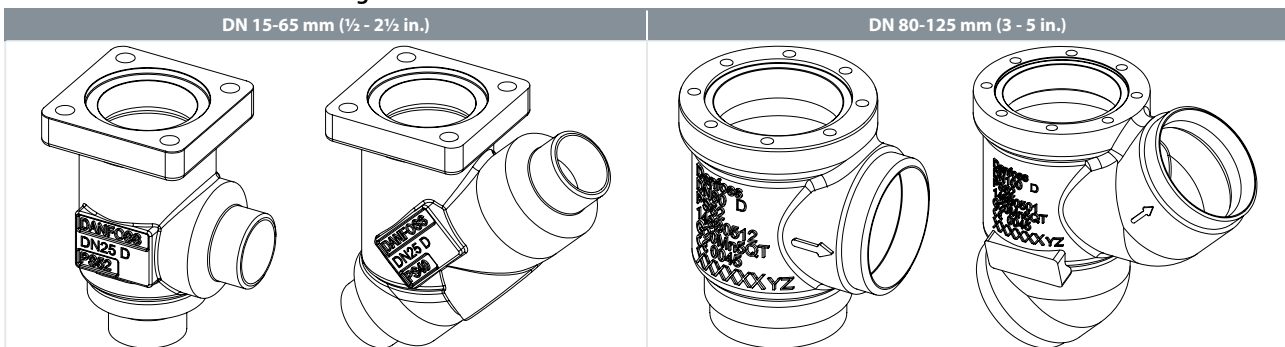

Table 21: FIA strainer valve housings w/different connections

Sizes [DN]		Valve Housing SVL	
		Butt weld F	
mm	in.	ANG	STR
15	½	148B6414	148B6424
20	¾	148B6415	148B6425
25	1	148B6416	148B6426
32	1¼	148B6417	148B6427
40	1½	148B6418	148B6428
50	2	148B6419	148B6429
65	2½	148B6420	148B6430
80	3	148B6421	148B6431
100	4	148B6422	148B6432
125	5	148B6423	148B6433

Strainer housing, type FIA with butt-weld connection F

Table 22: FIA complete top FIA complete topgaskets and bolts

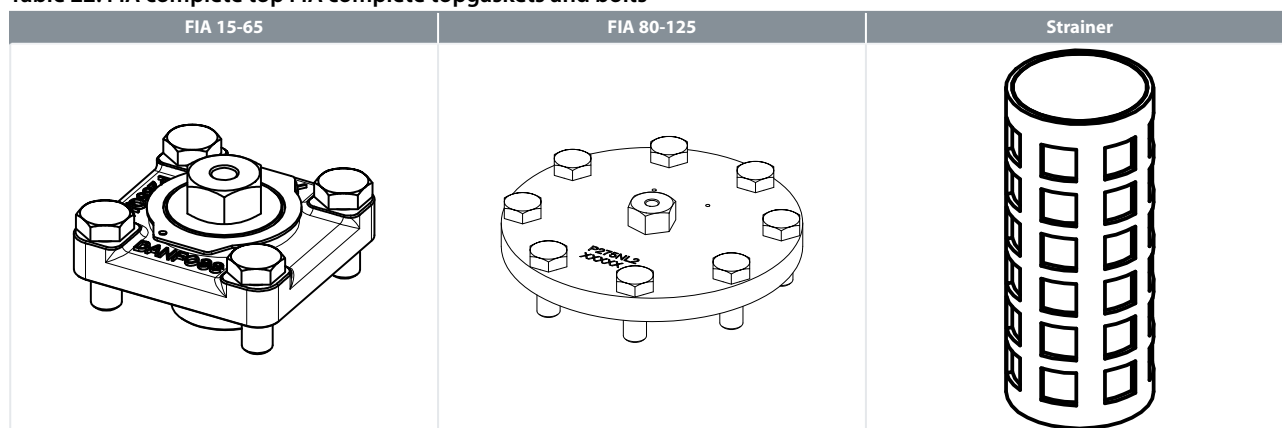

Table 23: FIA complete top part including gaskets and bolts

Sizes [DN]		Complete top part FIA	Strainer Element 100µ 150 mesh	Strainer Element 150µ 100 mesh	Strainer Element 250µ 72 mesh	Strainer Element 500µ 38 mesh	Pleated Strainer element 150µ 100 mesh	Pleated Strainer element 250µ 72 mesh	Pleated Strainer element 500µ 38 mesh
mm	in.								
15	½	148B5284	148H3122	148H3124	148H3126	148H3128	148H3303	-	-
20	¾								
25	1								
32	1¼	148B5484	148H3123	148H3125	148H3127	148H3129	148H3304	148H3269	-
40	1½								
50	2	148B5748	148H3157	148H3130	148H3138	148H3144	148H3179	148H3184	148H3189
65	2½	148B5832	-	148H3131	148H3139	148H3145	148H3180	148H3185	148H3190
80	3	148B5922	-	148H3119	148H3120	148H3121	148H3181	148H3186	148H3191
100	4	148B6024	-	148H3132	148H3140	148H3146	148H3182	148H3187	148H3192
125	5	148B6122	-	148H3133	148H3141	148H3147	148H3183	148H3188	148H3193

Certificates, declarations and approvals

The list contains all certificates, declarations, and approvals for this product type. Individual code number may have some or all of these approvals, and certain local approvals may not appear on the list.

Some approvals may change over time. You can check the most current status at danfoss.com or contact your local Danfoss representative if you have any questions.

Table 24: Certificates, declarations and approvals

File name	Document type	Document topic	Approval Authority
19.10048.266	Marine - Safety Certificate		RMRS
RU Д-ДК.БЛ08.В.00828_19	EAC Declaration	Machinery & Equipment	EAC
0045 202 1204 Z 00354 19 D 001(00)	Pressure - Safety Certificate		TÜV
03709-F0 BV	Marine - Safety Certificate		BV
RU C-ДК.БЛ08.В.01095_20	Pressure - Safety Certificate	PED	EAC
TAP000000S Rev. 1	Marine - Safety Certificate		DNV GL
MD 033F0691.AE	Manufacturers Declaration	RoHS	Danfoss
0045 202 1204 Z 00355 19 D 001(00)	Pressure - Safety Certificate		TÜV
033F0453.AD	Manufacturers Declaration	ATEX	Danfoss
EU 033F0685.AK	EU Declaration	EMCD/PED	Danfoss
MD 033F0686.AH	Manufacturers Declaration	PED	Danfoss

Pressure Equipment Directive (PED)

FIA strainers are approved in accordance with the European standard specified in the Pressure Equipment Directive and are CE marked. For further details / restrictions - see Installation Instruction.

Table 25: Pressure Equipment Directive (PED)

	Nominal bore	DN £ 25 (1 in.)	DN 32-80 mm (1¼ - 3 in.)	DN 100-200 mm (4-8 in.)
	Classified for	Fluid group I		
	Category	Article 3, paragraph 3	II	III

Online support

Danfoss offers a wide range of support along with our products, including digital product information, software, mobile apps, and expert guidance. See the possibilities below.

The Danfoss Product Store



The Danfoss Product Store is your one-stop shop for everything product related—no matter where you are in the world or what area of the cooling industry you work in. Get quick access to essential information like product specs, code numbers, technical documentation, certifications, accessories, and more.

Start browsing at store.danfoss.com.

Find technical documentation



Find the technical documentation you need to get your project up and running. Get direct access to our official collection of data sheets, certificates and declarations, manuals and guides, 3D models and drawings, case stories, brochures, and much more.

Start searching now at www.danfoss.com/en/service-and-support/documentation.

Danfoss Learning



Danfoss Learning is a free online learning platform. It features courses and materials specifically designed to help engineers, installers, service technicians, and wholesalers better understand the products, applications, industry topics, and trends that will help you do your job better.

Create your Danfoss Learning account for free at www.danfoss.com/en/service-and-support/learning.

Get local information and support



Local Danfoss websites are the main sources for help and information about our company and products. Find product availability, get the latest regional news, or connect with a nearby expert—all in your own language.

Find your local Danfoss website here: www.danfoss.com/en/choose-region.

Spare Parts



Get access to the Danfoss spare parts and service kit catalog right from your smartphone. The app contains a wide range of components for air conditioning and refrigeration applications, such as valves, strainers, pressure switches, and sensors.

Download the Spare Parts app for free at www.danfoss.com/en/service-and-support/downloads.

Coolselector®2 - find the best components for you HVAC/R system



Coolselector®2 makes it easy for engineers, consultants, and designers to find and order the best components for refrigeration and air conditioning systems. Run calculations based on your operating conditions and then choose the best setup for your system design.

Download Coolselector®2 for free at coolselector.danfoss.com.

Danfoss A/S

Climate Solutions • danfoss.com • +45 7488 2222

Any information, including, but not limited to information on selection of product, its application or use, product design, weight, dimensions, capacity or any other technical data in product manuals, catalogues descriptions, advertisements, etc. and whether made available in writing, orally, electronically, online or via download, shall be considered informative, and is only binding if and to the extent, explicit reference is made in a quotation or order confirmation. Danfoss cannot accept any responsibility for possible errors in catalogues, brochures, videos and other material. Danfoss reserves the right to alter its products without notice. This also applies to products ordered but not delivered provided that such alterations can be made without changes to form, fit or function of the product.

All trademarks in this material are property of Danfoss A/S or Danfoss group companies. Danfoss and the Danfoss logo are trademarks of Danfoss A/S. All rights reserved.